

BENELLI

1/2x5/16 (428)

125CC
250CC
2 cil.

416-12	241.612
13	241.613
14	241.614
15	241.615
16	241.616
17	241.617

E 416

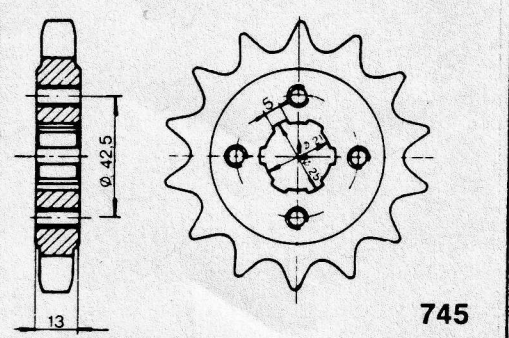

BENELLI

5/8x3/8 (530)

500cc 4 cil, 750cc, 6 cil

745-17	274.517
--------	---------

745

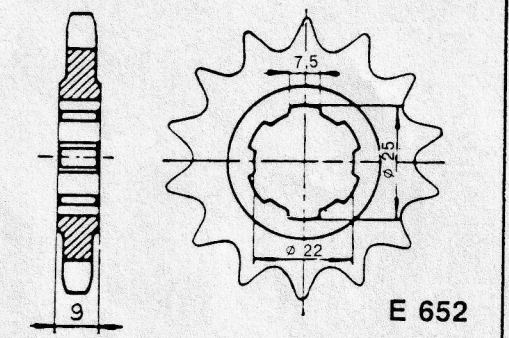

BULTACO

5/8x1/4 (520)

175/250cc CR
MK2 Pursang, Matador
250MK II Frontera, 350cc Sherpa

652-11	265.211
12	265.212
13	265.213

E 652

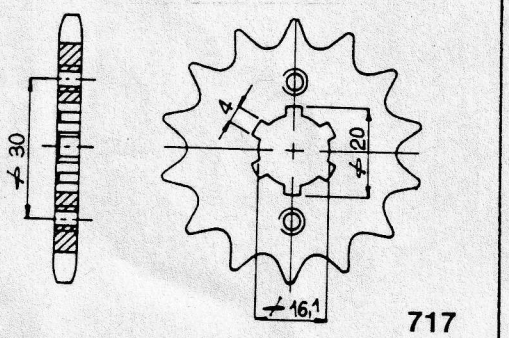

CAGIVA

5/8x1/4 (520)

WMX125 '82/84
WMX125GP '85
WRX125RG, WMX250

717-12	271.712
13	271.713
14	271.714

717

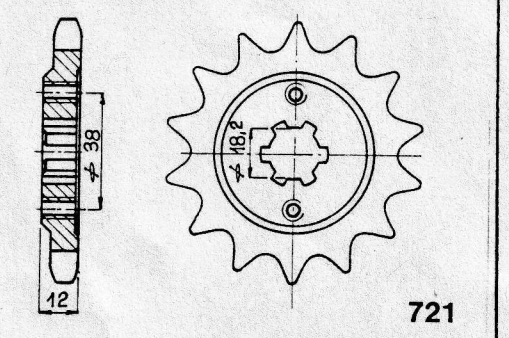

CAGIVA

5/8x3/8 (530)

350cc SST
350cc SX

721-15	272.115
17	272.117

721

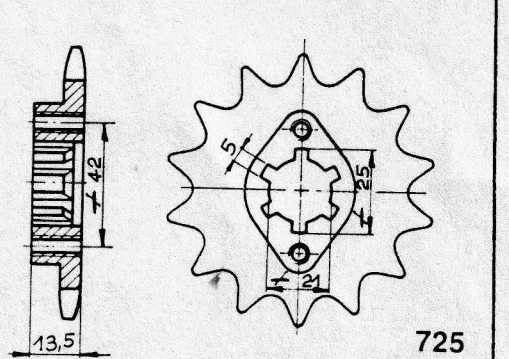

CAGIVA

5/8x3/8 (530)

350 Alazzurra '84/85, Elephant 650
650 Alazzurra '84/85, Elephant 650

725-14	272.514
15	272.515

725

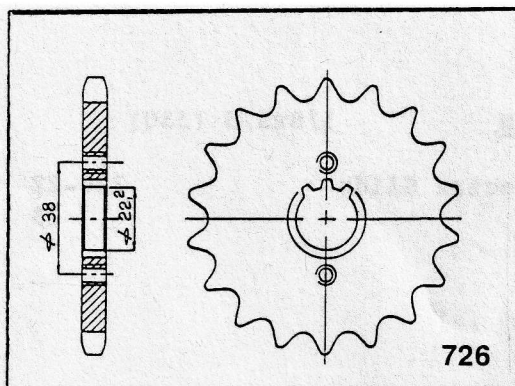

CAGIVA

5/8x3/8 (530)

Elefant 750 '87

726-14

272.614

15

272.615

726

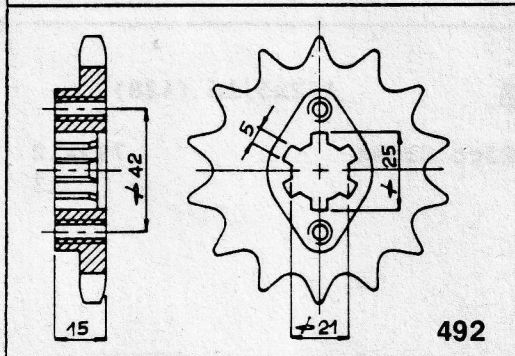

DUCATI

5/8x3/8 (530)

500 Pantah SL, 350 Pantah '81

492-14

249.214

600 Pantah SL, TL

15

249.215

492

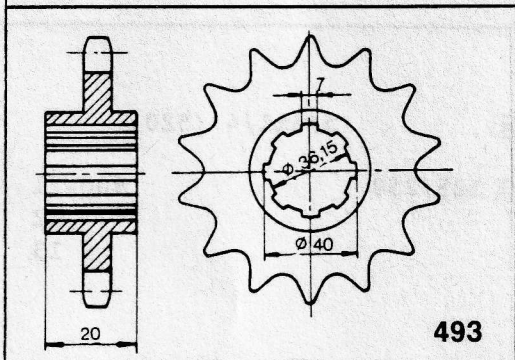

DUCATI

5/8x3/8 (530)

500 Desmo

493-15

249.315

750GT, S, SS, 850GT, GTS

16

249.316

900SS, SS2, 900SS Replica

16

493

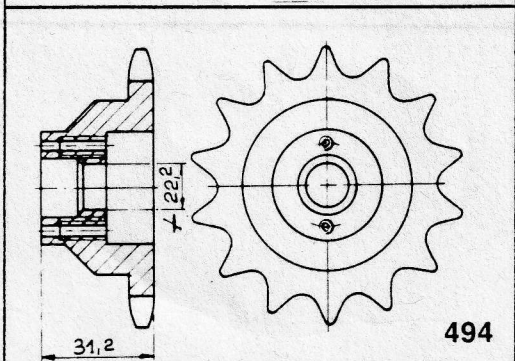

DUCATI

5/8x1/4 (520)

FI 750 Montjuich '87

494-14

249.414

750 Santa Monica '88

15

249.415

materiaal: K2D

494

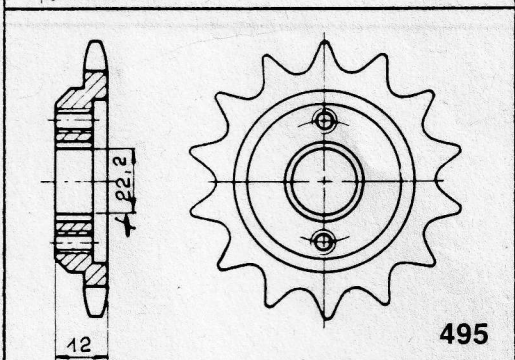

DUCATI

5/8x1/4 (520)

PASO 750 '87

495-15

249.515

750 LAGUNA Seca '87

materiaal: K2D

495

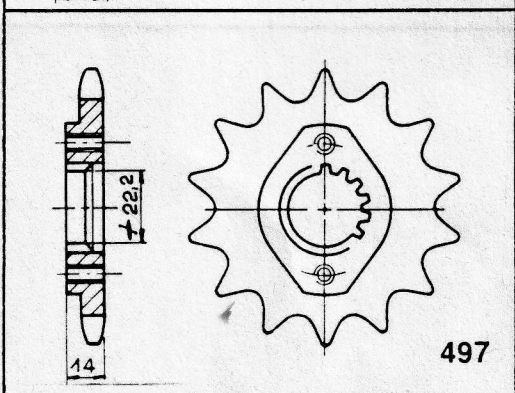

DUCATI

5/8x3/8 (530)

FI 50 '87

497-15

249.715

497

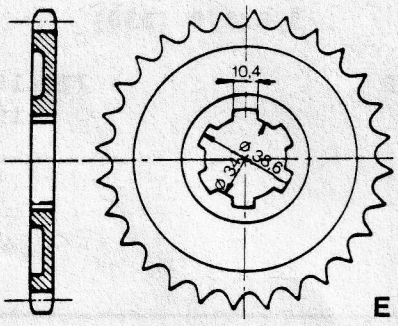

E 720

H. DAVIDSON

5/8x3/8 (530)

1300cc Electra Glide

720-22
23

272.022
272.023

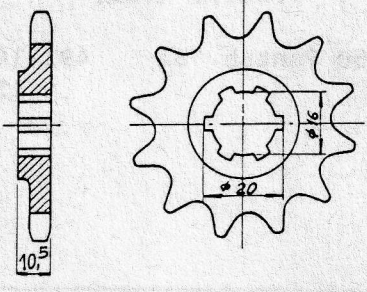

799

HIRO MOTOR

1/2x5/16 (428)

Aprilia 125cc Cross

799-12
13

279.912
279.913

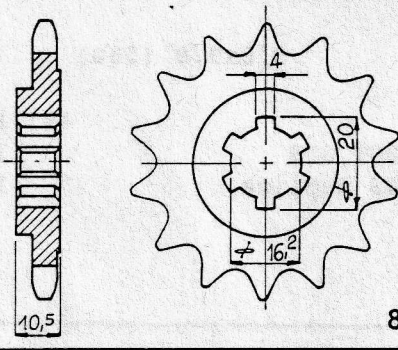

800

HIRO MOTOR

5/8x1/4 (520)

Aprilia RC 125/250
MX125

800-11
12
13

280.011
280.012
280.013

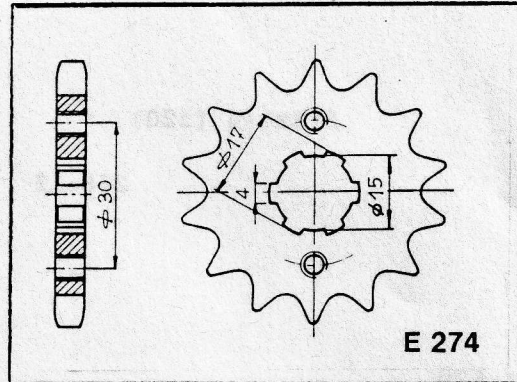

E 274

HONDA 1/2x5/16 (428)
 XL 100S, H100 274-15 227.415
 MTX80 RZ '87

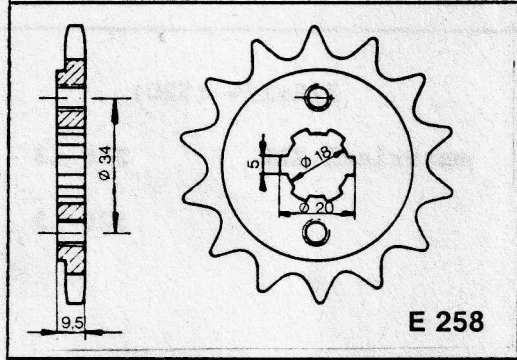

E 258

HONDA 1/2x5/16 (428)
 CB100, CB125, XL125S 258-13 225.813
 CR125 ELSINORE 16 225.816
 CB175

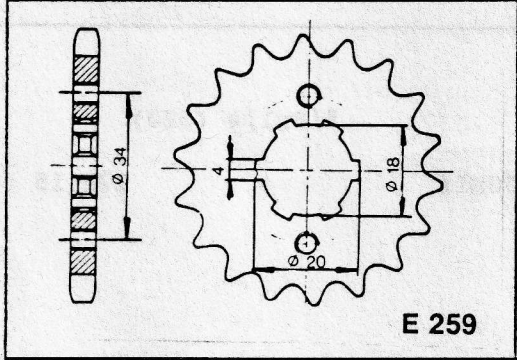

E 259

HONDA 1/2x5/16 (428)
 CB100 259-13 225.913
 CB125 J1 Cil. 14 225.914
 XL100, XL125, XL125R, XL185 15 225.915
 MTX125, GG125, CM125, CM185, CM200T 16 225.916

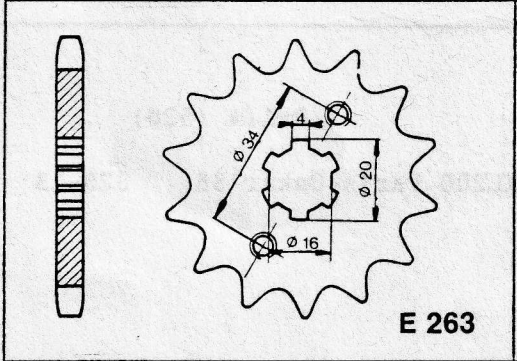

E 263

HONDA 1/2x5/16 (428)
 CB125 Benly C92 263-13 226.313
 CB125K2-K3, 14 226.314
 CB175K3 15 226.315
 SL90, CD90, M1, K1 16 226.316

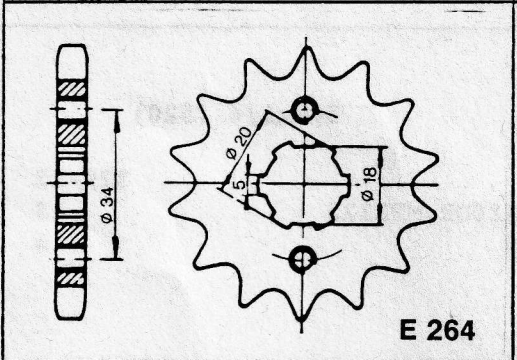

E 264

HONDA 1/2x5/16 (428)
 C90, C100 '70 264-13 226.413
 CB125K3 14 226.414
 CD175 15 226.415
 16 226.416

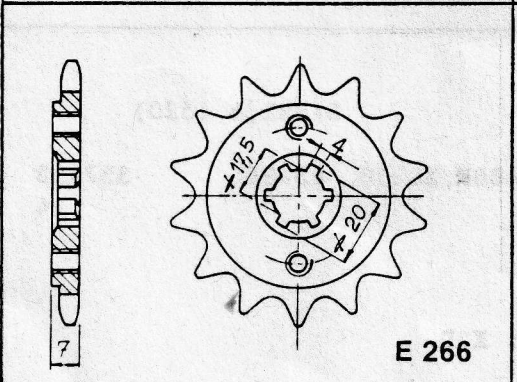

E 266

HONDA 5/8x1/4 (520)
 CR125RA '79/85 266-12 226.612
 CR125, XR250, XL250RE '84 13 226.613
 14 226.614

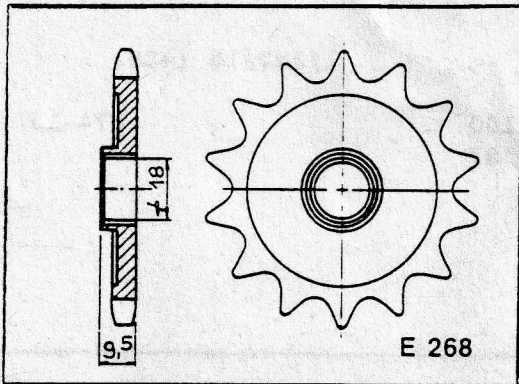

HONDA 5/8x1/4 (520)
 CR125 '86 268-13 226.813
materiaal: K2D

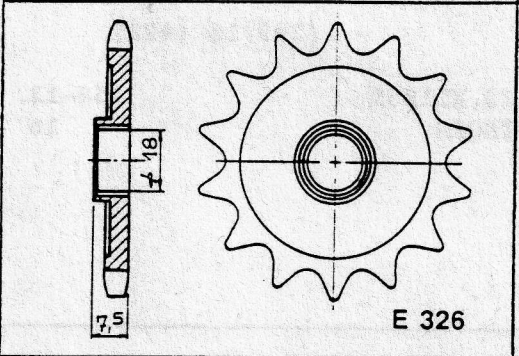

HONDA 5/8x1/4 (520)
 CR125 '87 **materiaal K2D** 326-13 232.613
 CR125 '87 326-13 232.617

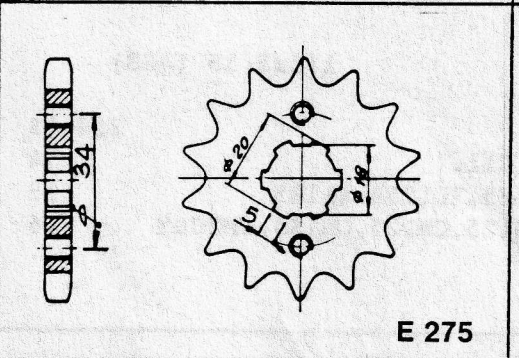

HONDA 5/8x1/4 (520)
 CB200, CR250MII 275-15 227.515

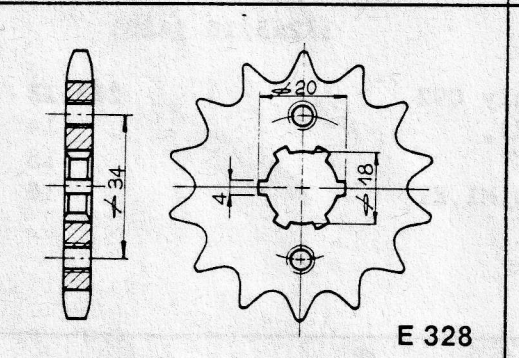

HONDA 5/8x1/4 (520)
 XL200RII, XL200 Paris-Dakar '86 328-13 232.813

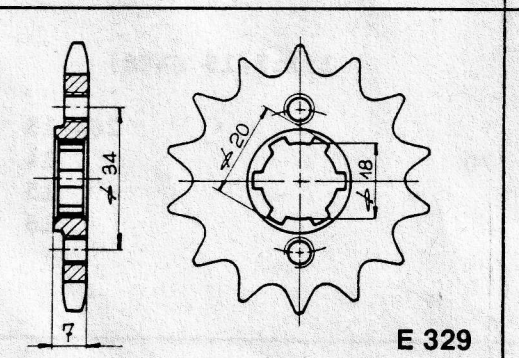

HONDA 5/8x1/4 (520)
 XL200R, MTX200R, MTX125 329-12 232.912
 NS125F '86 13 232.913
 14 232.914

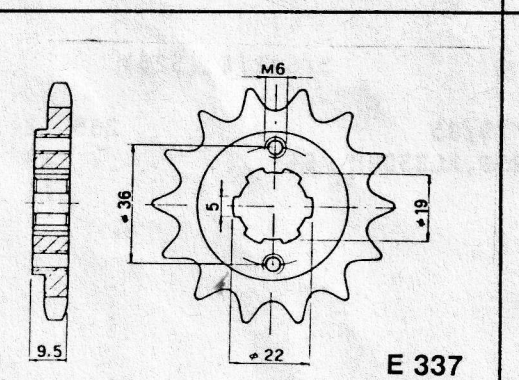

HONDA 5/8x1/4 (520)
 CR250R, CR480R, XL250 '85-86 337-13 233.713
 CM250C 14 233.714
materiaal: K2D

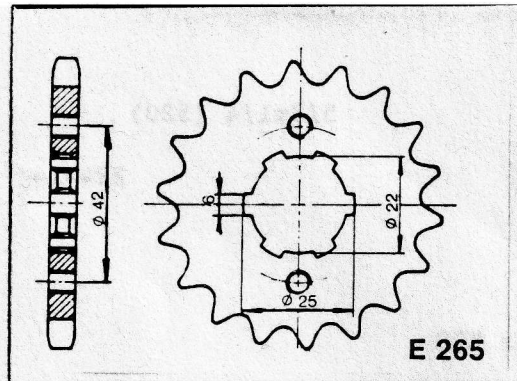

HONDA 5/8x1/4 (520)
 XL250S-'81 265-14 226.514

E 265

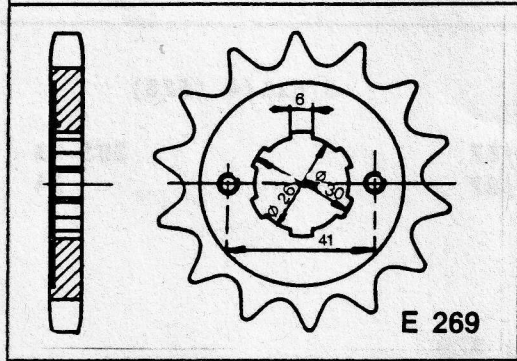

HONDA 5/8x3/8 (530)
 250 Super Dream Sp 269-13 226.913
 350 Super Dream Sp 14 226.914
 15 226.915
 16 226.916

E 269

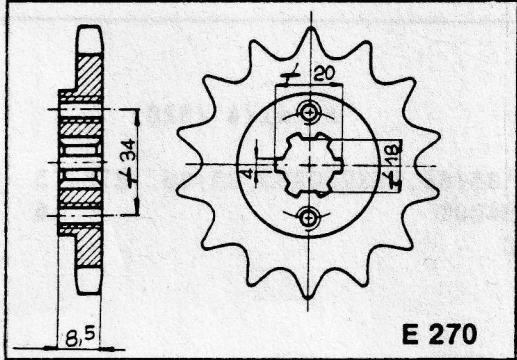

HONDA 5/8x1/4 (520)
 CM250C-D '85 270-14 227.014

E 270

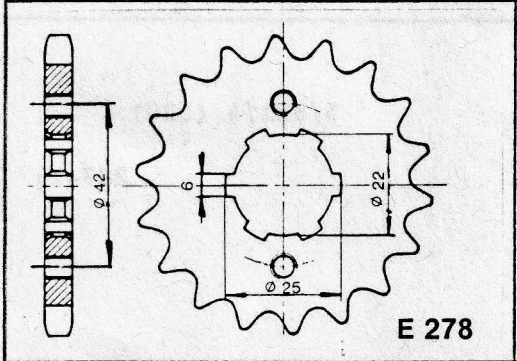

HONDA 5/8x3/8 (530)
 CB250T/N, CB450, CB500T 278-15 227.815
 CB250G, CB360G, NS400R, CB400T/N 16 227.816
 CB350F, CB400F 17 227.817

E 278

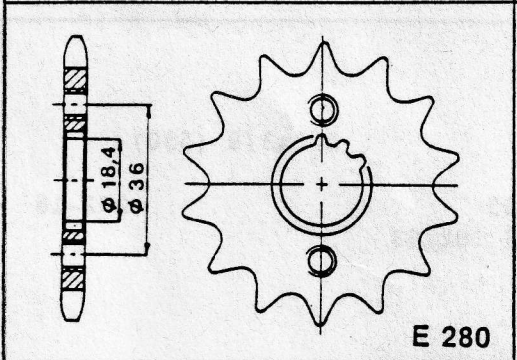

HONDA 5/8x1/4 (520)
 NX250 Enduro '88 280-13 228.013

E 280

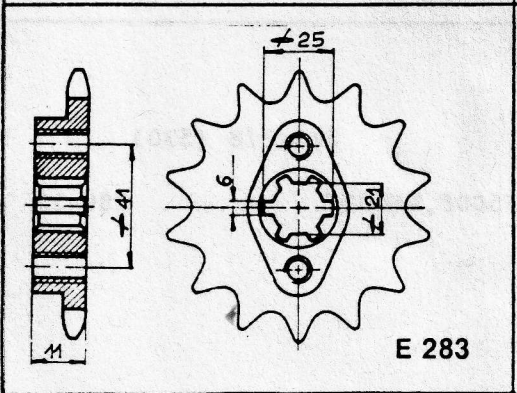

HONDA 5/8x1/4 (520)
 VT250FD '84 283-14 228.314

E 283

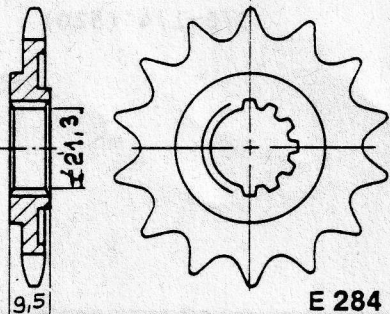
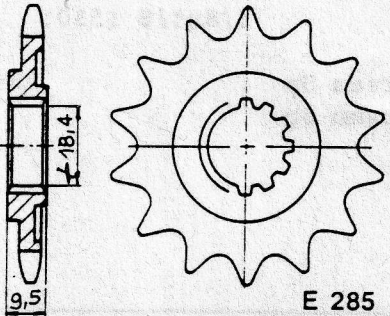
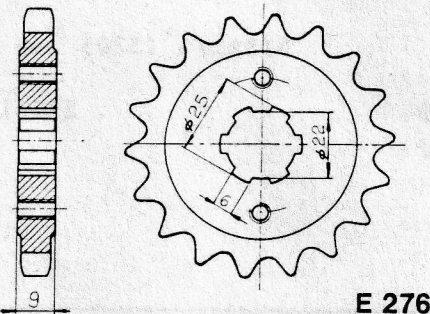
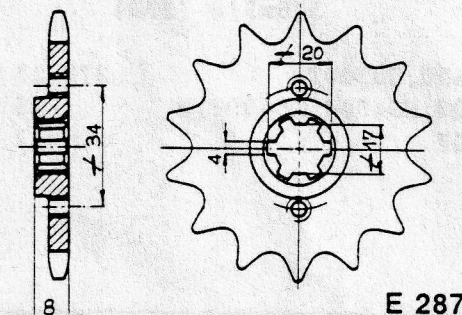
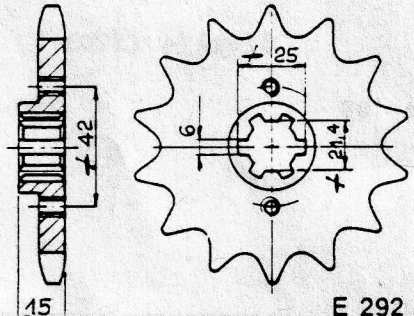
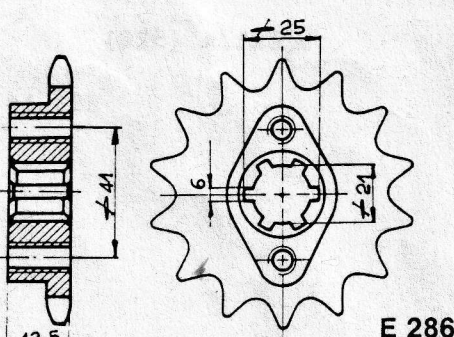
 <p>E 284</p>	<p><u>HONDA</u> 5/8x1/4 (520)</p> <p>CR250, '88 284-14 228.414</p> <p>materiaal: K2D</p>
 <p>E 285</p>	<p><u>HONDA</u> 5/8x1/4 (520)</p> <p>CR250 '86/87 285-13 228.513 CR500 '86/87 14 228.514</p> <p>materiaal: K2D</p>
 <p>E 276</p>	<p><u>HONDA</u> 5/8x1/4 (520)</p> <p>CBX250RSE '85/86, CBX250RSE '85/86 276-15 227.615 CB400NB, CM400T 16 227.616 CB250N/B/C</p>
 <p>E 287</p>	<p><u>HONDA</u> 5/8x1/4 (520)</p> <p>XL350R '85 287-14 228.714</p>
 <p>E 292</p>	<p><u>HONDA</u> 5/8x3/8 (530)</p> <p>NS400RF '85 292-16 229.216 CBX500F/FZ '82/83</p>
 <p>E 286</p>	<p><u>HONDA</u> 5/8x3/8 (530)</p> <p>CBX400F, VF500F, VF400F 286-15 228.615</p>

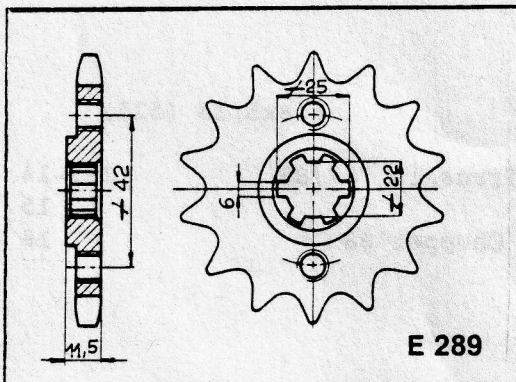
HONDA

5/8x3/8 (530)

FT500 '83/84

289-15

228.915

CB450N '85

16

228.916

E 289

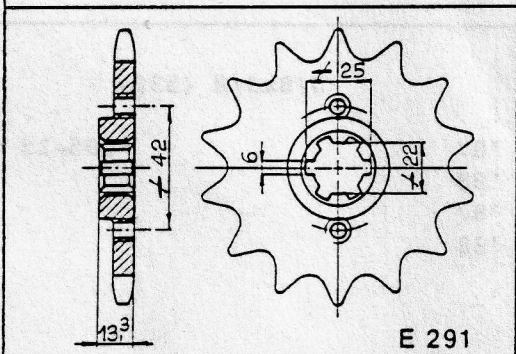
HONDA

5/8x5/16 (525)

CB450S-G '86/88

291-16

229.116

E 291

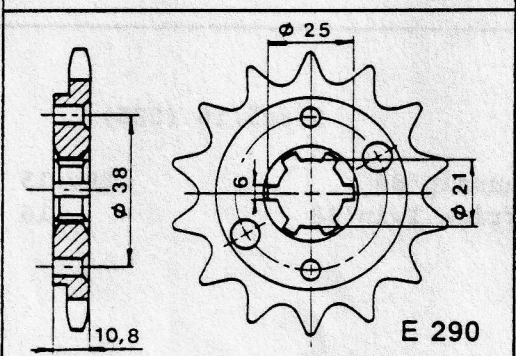
HONDA

5/8x5/16 (525)

XBR500 '85

290-15

229.015

14

229.014

E 290

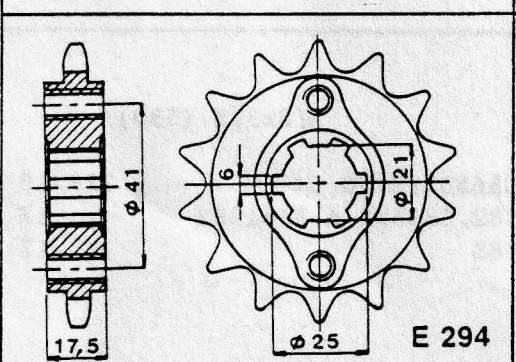
HONDA

5/8x5/16 (525)

XBR500H '87/88

294-14

229.414

15

229.415

E 294

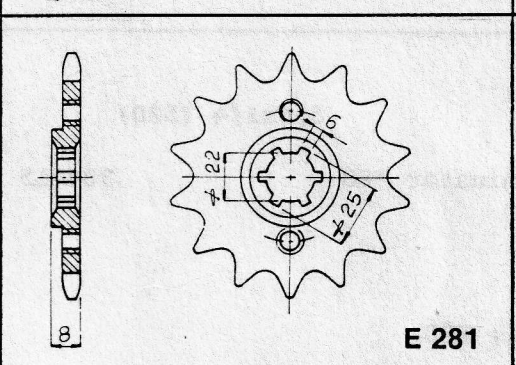
HONDA

5/8x1/4 (520)

CB250RS-A

281-13

228.113

XL250S '82-, XL500S, XR500, CB250RS

14

228.114

XL500R, XL600R, XL600LM-F '85

15

228.115

XL600RE-G '86

15

materiaal: K2D

E 281

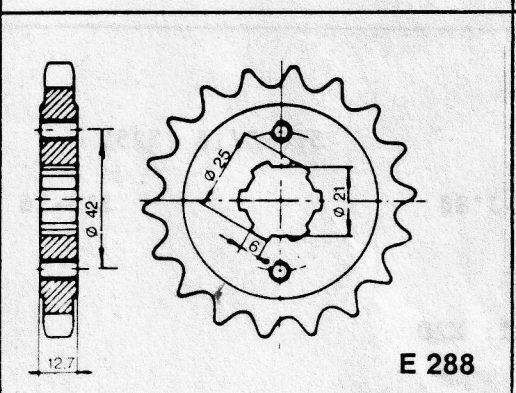
HONDA

5/8x3/8 (530)

CB400F

288-14

228.814

CB500, CB550, CB750K1-K6, F1

15

228.815

CB550K, CB550F, K3

17

228.817

18

228.818

E 288

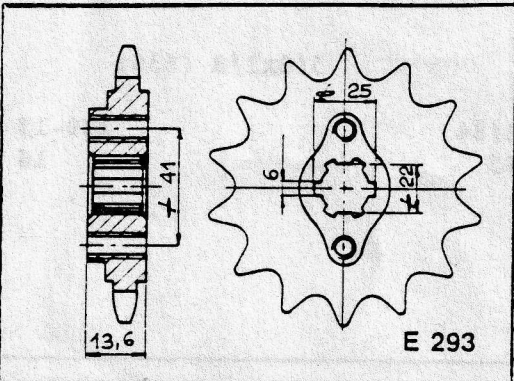

HONDA

5/8x5/16 (525)

XL600VH Transalp '87/88

293-14

229.314

15

229.315

VT600C-J Chopper '88

16

229.316

E 293

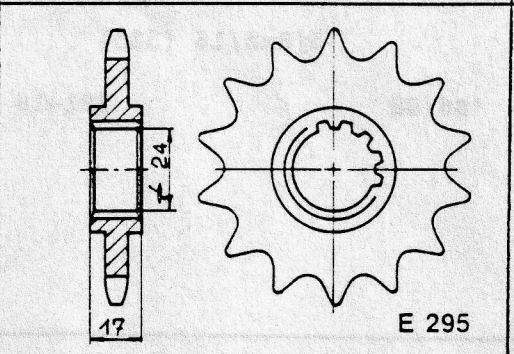

HONDA

5/8x3/8 (530)

CBR500FH '87

295-15

229.515

CBR500FJ '88

CBR600FH '87

CBR600FJ '88

E 295

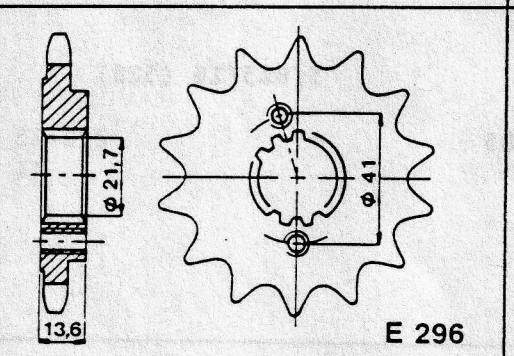

HONDA

5/8x5/16 (525)

XL600 Transalp '89

296-15

229.615

XR650 Africa Twin '88

16

229.616

E 296

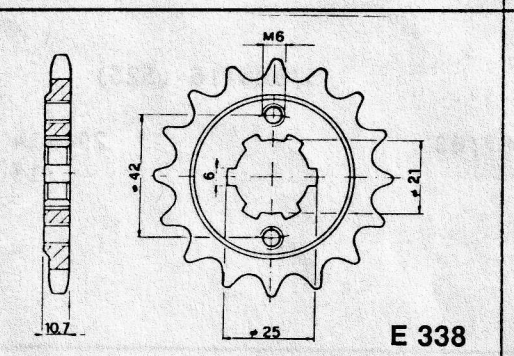

HONDA

5/8x3/8 (530)

CBX550F, CB650Z/C/SC

338-16

233.816

CB650Z-B '82, CB650C-A, B '81/82

17

233.817

CB650C-C '83

17

E 338

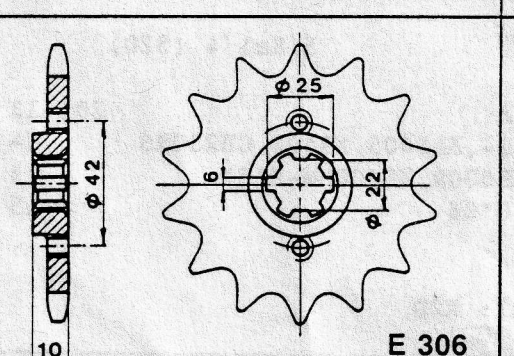

HONDA

5/8x1/4 (520)

NX650 Dominator '88

306-15

230.615

materiaal: K2D

E 306

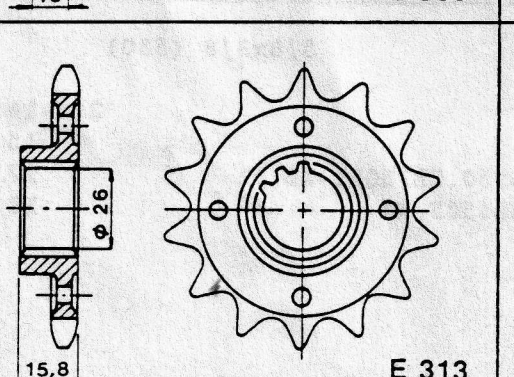

HONDA

5/8x5/16 (525)

VFR750 R-J '88

313-16

231.316

materiaal: K2D

E 313

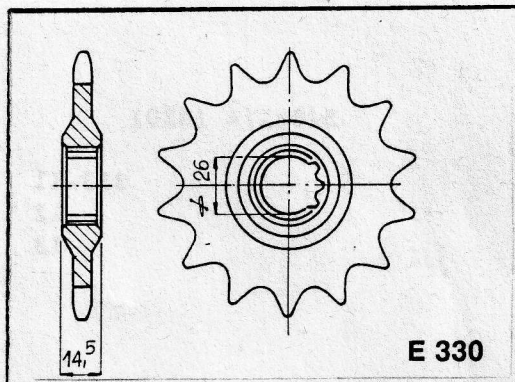

HONDA

3/4x3/8 (630)

CB750KZ

330-15

233.015

E 330

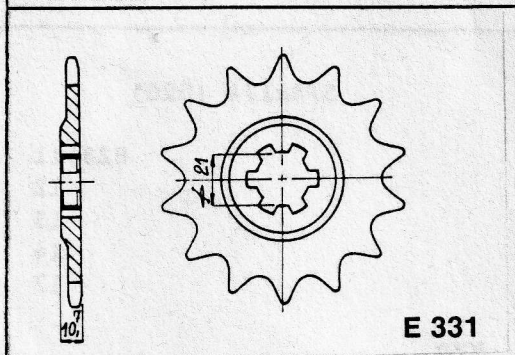

HONDA

3/4x3/8 (630)

CB750F2
CB750K7

331-14
15

233.114
233.115

E 331

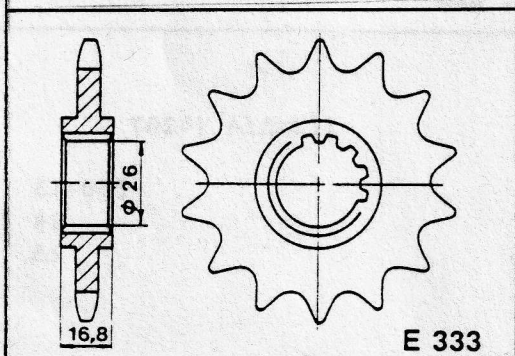

HONDA

5/8x3/8 (530)

VFR750F(J) '87/88

333-16

233.316

E 333

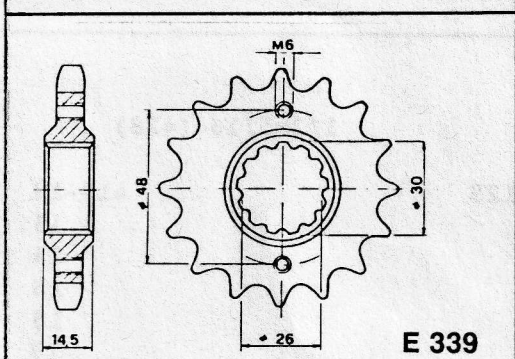

HONDA

5/8x3/8 (530)

CBX750F, VRF750F-G'86, VF1000F/R
VF750F, CB900F, CB1100R/F,
CBR1000FH'87/88
CB750FA/FB/FC/FD

339-16
17
17
18

233.916
233.917
233.918

E 339

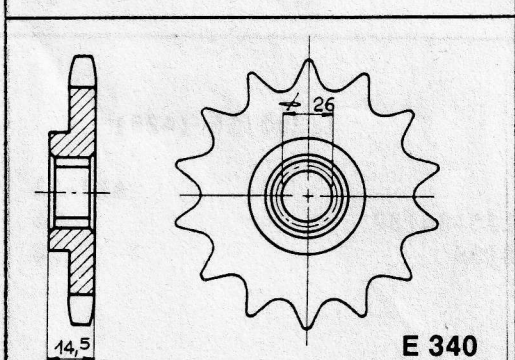

HONDA

5/8x3/8 (530)

CBX1000/B PRO-LINK

340-18

234.018

E 340

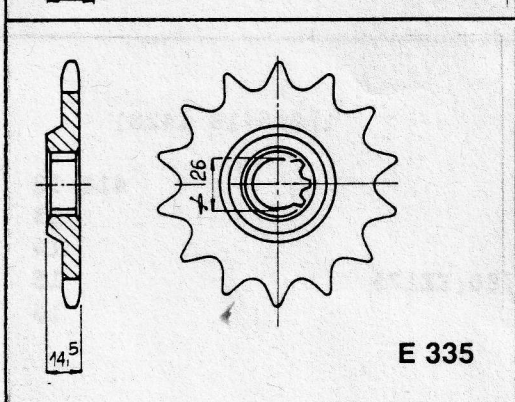

HONDA

3/4x3/8 (630)

CBX1000(Z)'79

335-15

233.515

E 335

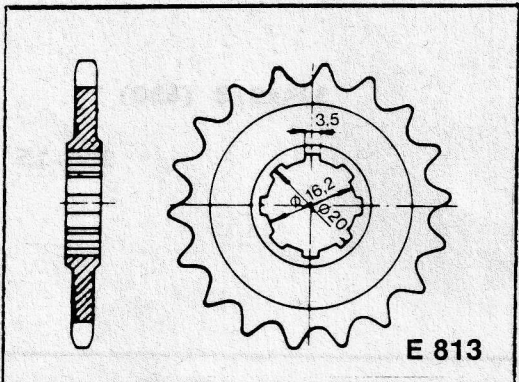

HUSQVARNA

5/8x1/4 (520)

- 175CR, RG
- 250CR, WG
- 350CR, WR
- 400CR, WR

- 813-11
- 12
- 13

- 281.311
- 281.312
- 281.313

E 813

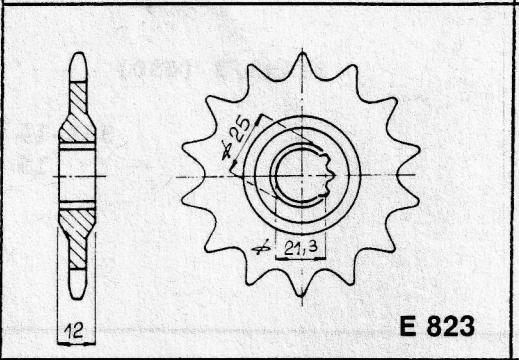

HUSQVARNA

5/8x1/4 (520)

- 250CR, WR
- 350CR, WR
- 390CR, WR
- 430CR, WR

- 823-11
- 12
- 13
- 14
- 17

- 282.311
- 282.312
- 282.313
- 282.314
- 282.317

E 823

materiaal: K2D

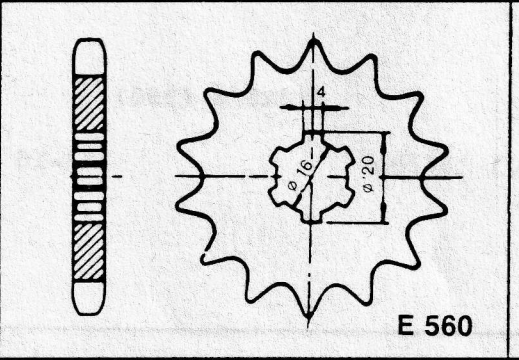

KAWASAKI

1/2x1/4 (420)

- KX80EF
- KX80F2

- 560-13
- 14
- 15

- 256.013
- 256.014
- 256.015

E 560

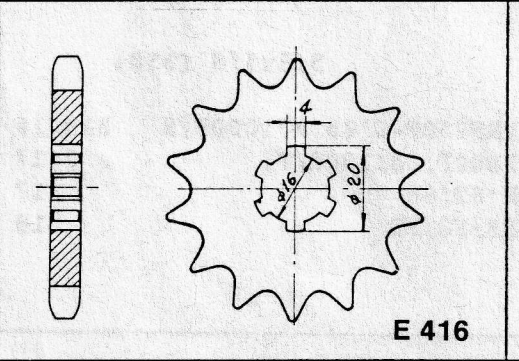

KAWASAKI

1/2x5/16 (428)

- KH100G, KX125
- KS125
- KE125
- KE175
- KS175

- 416-12
- 13
- 14
- 15
- 16
- 17

- 241.612
- 241.613
- 241.614
- 241.615
- 241.616
- 241.617

E 416

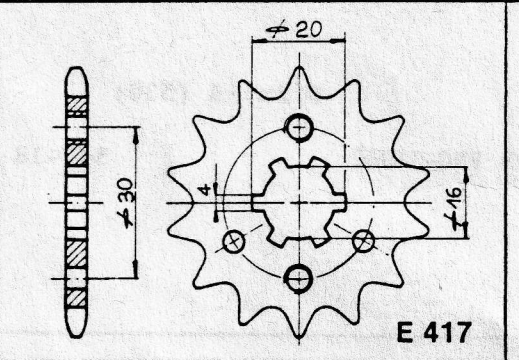

KAWASAKI

1/2x5/16 (428)

- AR125, KMX125 '86/87
- KMX200 '88/89

- 417-13
- 14
- 16

- 241.713
- 241.714
- 241.716

E 417

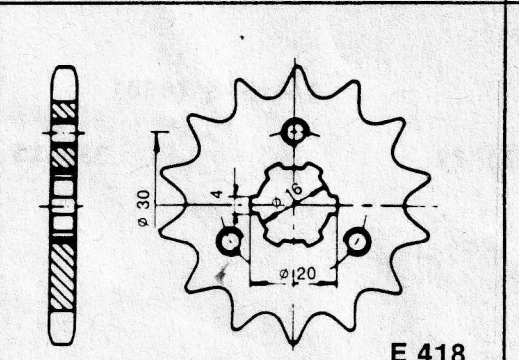

KAWASAKI

1/2x5/16 (428)

- KE125 '81
- KE125 '76/80, KE175

- 418-12
- 13
- 14
- 15
- 16

- 241.812
- 241.813
- 241.814
- 241.815
- 241.816

E 418

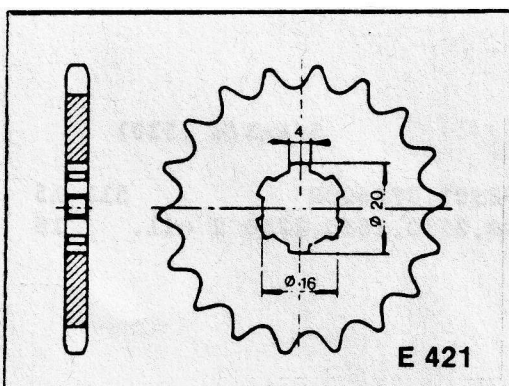

KAWASAKI

5/8x1/4 (520)

KX125C1 '84/88

421-11

242.111

KDX175

12

242.112

13

242.113

14

242.114

E 421

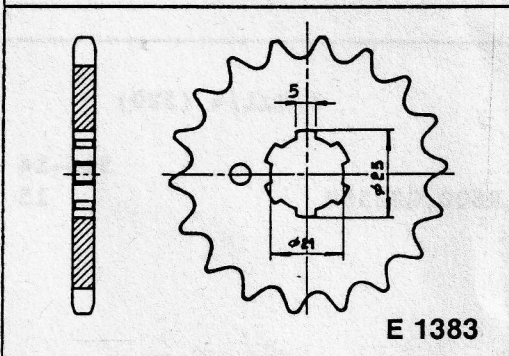

KAWASAKI

5/8x1/4 (520)

KL240

1383-11

208.311

Z200

12

208.312

13

208.313

14

208.314

E 1383

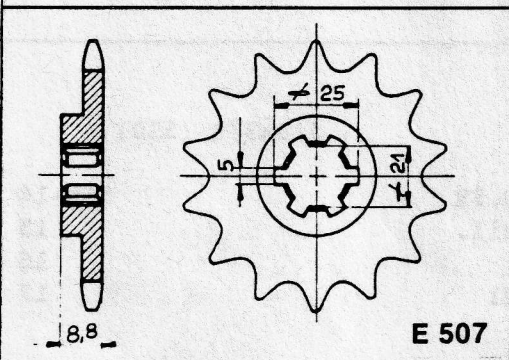

KAWASAKI

5/8x1/4 (520)

KX250C2 '85, KX500'85

507-14

250.714

E 507

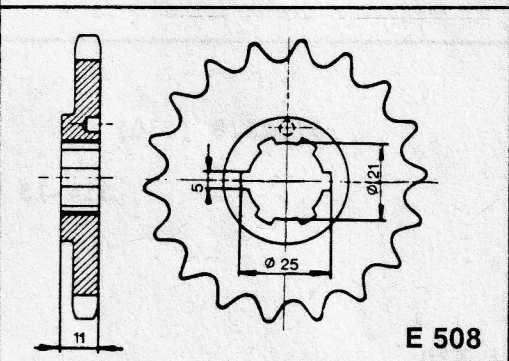

KAWASAKI

5/8x3/8 (530)

S2 350/3

508-14

250.814

KZ400

15

250.815

Z250, 500cc H1, KH400, 750cc H2

16

250.816

E 508

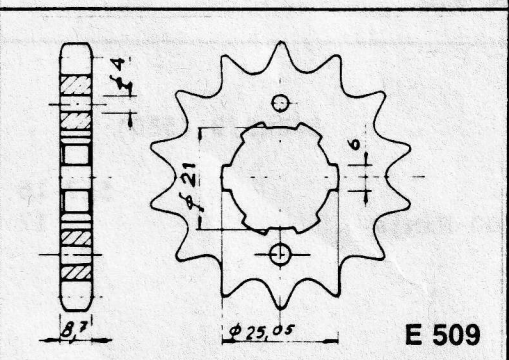

KAWASAKI

5/8x3/8 (530)

Z400B, Z440LTD, KZ400

509-15

250.915

E 509

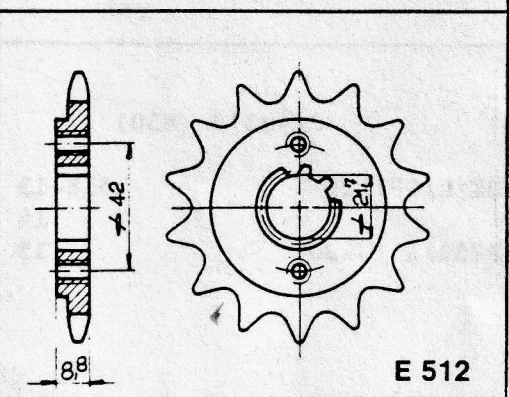

KAWASAKI

5/8x1/4 (520)

GPZ400, ZX550A1 GPZ

512-16

251.216

E 512

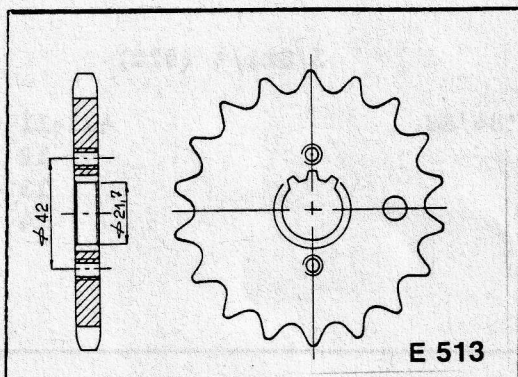

E 513

KAWASAKI

5/8x3/8 (530)

CSR305, GPZ305, GPZ600R

513-15

251.315

Z400J, Z500, Z550, Z650, Z750 2 cil. 16

251.316

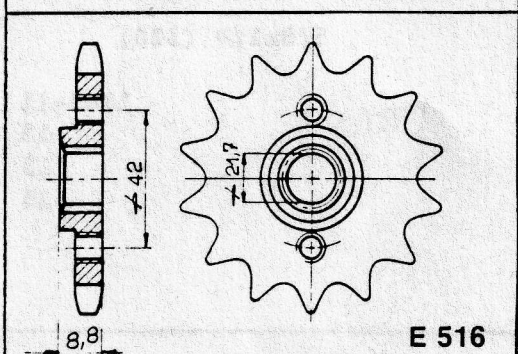

E 516

KAWASAKI

5/8x1/4 (520)

KLR500

516-14

251.614

KLR500, KLR600, GPZ550

15 251.615

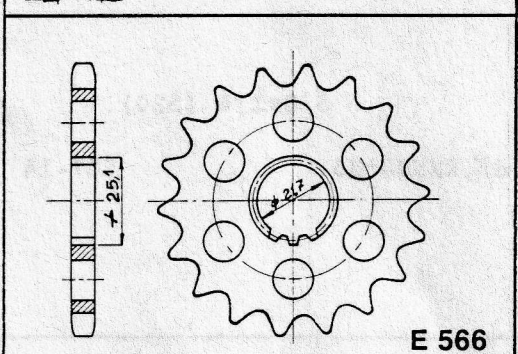

E 566

KAWASAKI

5/8x3/8 (530)

Z650B, C, D, SR

566-14

256.614

Z750B 2 cil.

15 256.615

Z750D2

16 256.616

Z750LTD-Y1

17 256.617

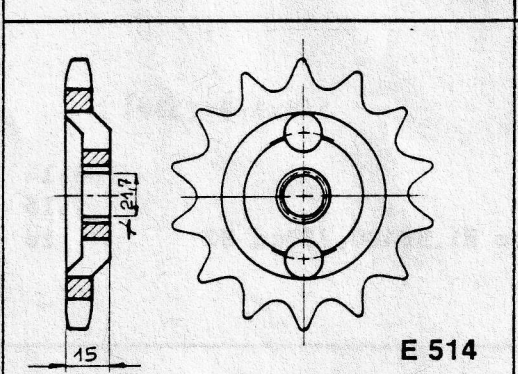

E 514

KAWASAKI

3/4x3/8 (630)

GPZ750ZX

514-15

251.415

materiaal: K2D

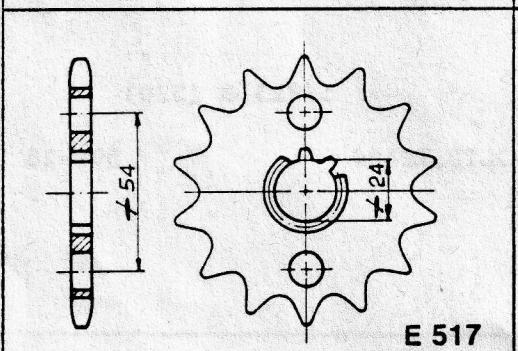

E 517

KAWASAKI

5/8x3/8 (530)

GPZ750R

517-16

251.716

GPZ900R, 900 Ninja

17 251.717

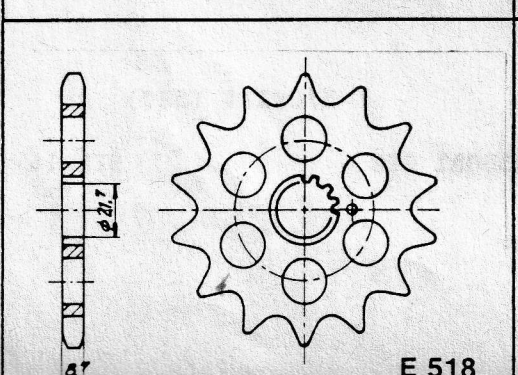

E 518

KAWASAKI

3/4x3/8 (630)

Z650F, Z750E/L/GP/LTD

518-13

251.813

Z750E/L

14 251.814

Z1/Z900, GP750ZX TURBO

15 251.815

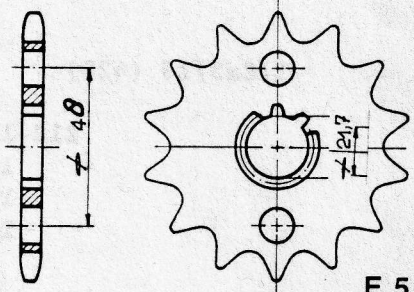
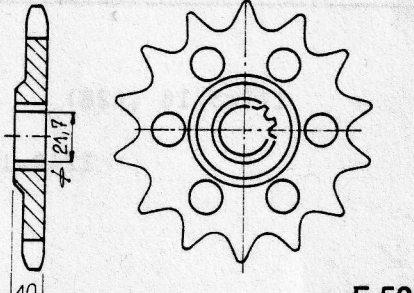
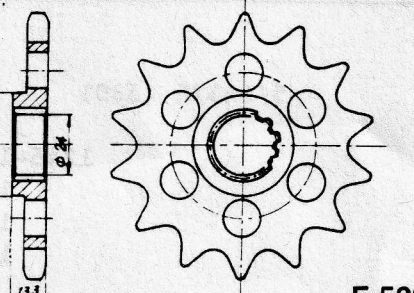
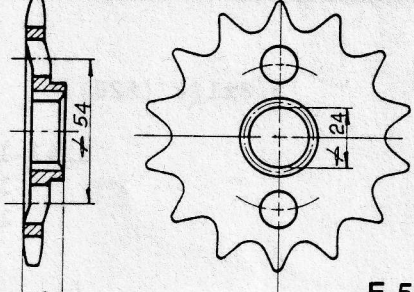
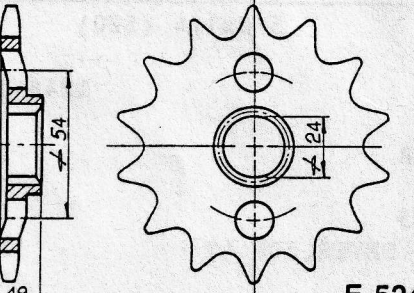
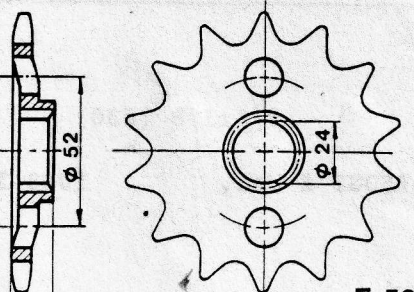
 <p>E 519</p>	<p><u>KAWASAKI</u> 5/8x3/8 (530)</p> <p>ZXR750'89 519-16 251.916</p>
 <p>E 521</p>	<p><u>KAWASAKI</u> 3/4x3/8 (630)</p> <p>Z900, Z1000, Z1000MKII 521-15 252.115</p>
 <p>E 522</p>	<p><u>KAWASAKI</u> 3/4x3/8 (630)</p> <p>Z1000J/R, Z1100GP-'82, Z1000LTD 522-15 252.215</p> <p>materiaal: K2D</p>
 <p>E 523</p>	<p><u>KAWASAKI</u> 3/4x3/8 (630)</p> <p>GP1100ZX 523-15 252.315</p> <p>materiaal: K2D</p>
 <p>E 524</p>	<p><u>KAWASAKI</u> 3/4x3/8 (632)</p> <p>GPZ1000RX'86/87 524-15 252.415</p> <p>materiaal: K2D</p>
 <p>E 525</p>	<p><u>KAWASAKI</u> 5/8x3/8 (532)</p> <p>ZX10 '88 525-17 252.517</p> <p>materiaal: K2D</p>

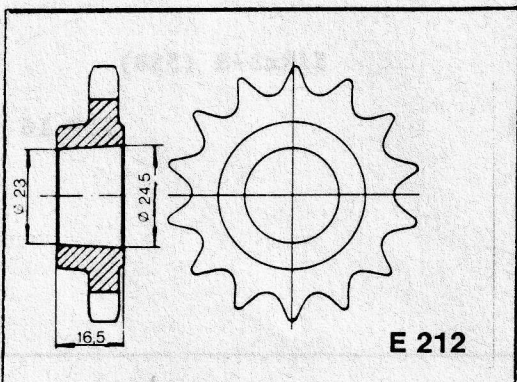

KTM

1/2x5/16 (428)

100cc
125cc
Sachs

212-11
12
13
14

221.211
221.212
221.213
221.214

E 212

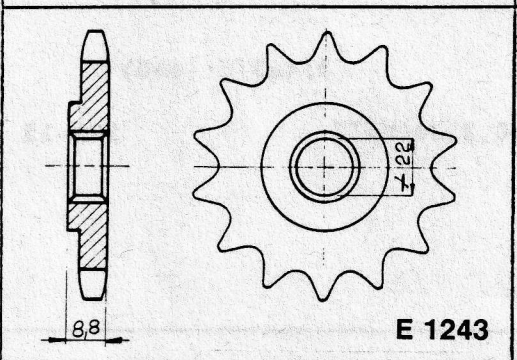

KTM

1/2x5/16 (428)

125MX '84

1243-16

204.316

E 1243

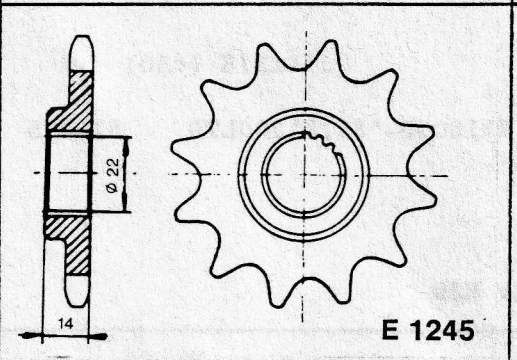

KTM

5/8x3/8 (530)

175GS, CR
250GS, CR
400GS, CR

1245-11
12
13
14

204.511
204.512
204.513
204.514

E 1245

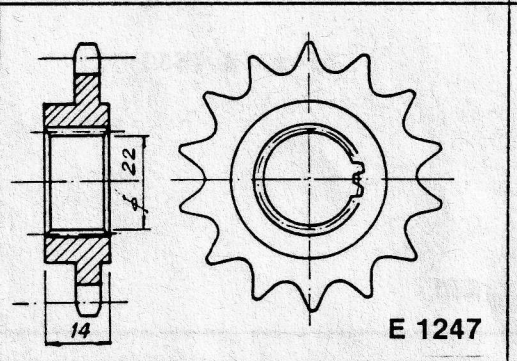

KTM

5/8x1/4 (520)

125T 51
125GS, CR, RG
175GS, CR, RG

1247-11
12
14

204.711
204.712
204.714

E 1247

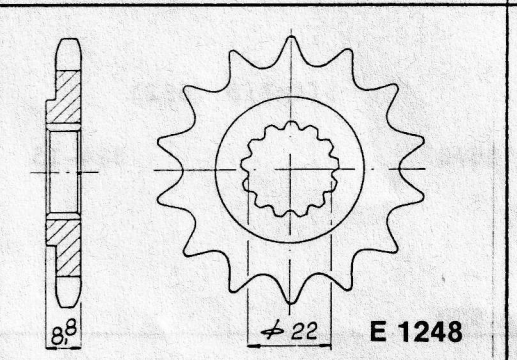

KTM

5/8x1/4 (520)

125MX 80
125RV, LC, GS
125 PRO LEVER
250 GS '83/85
MX250LC '83/85
350GS, 495PRO LEVER, 500 4T

1248-11
12
13
14
15
16

204.811
204.812
204.813
204.814
204.815
204.816

materiaal: K2D

E 1248

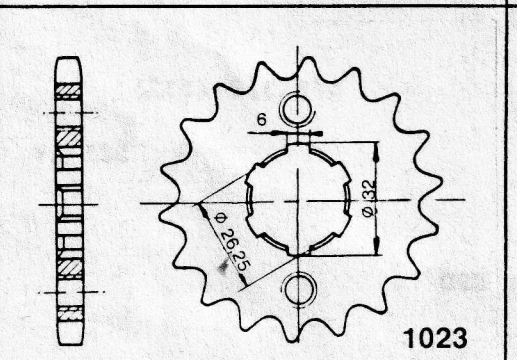

LAVERDA

5/8x3/8 (530)

750SF 5 Vel, 750GT 5 Vel.

1023-19

202.319

1023

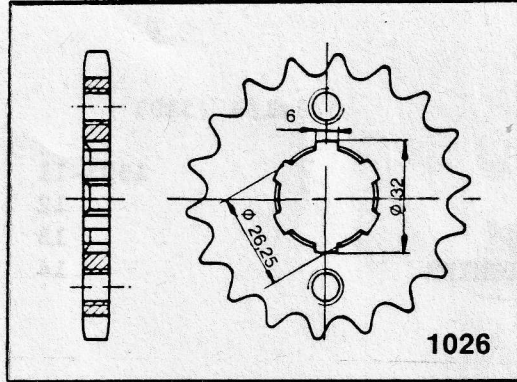

LAVERDA

3/4x3/8 (630)

1000RGA Jota, 1000RGS Corsa
1000RGS Executive, 1200TS

1026-16
16

202.616

1026

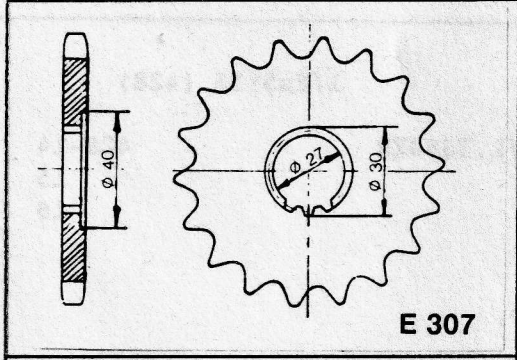

MAICO

5/8x1/4 (520)

250MC, GS
400MC, GS, 490MC, GS

307-11
12
13

230.711
230.712
230.713

E 307

materiaal: K2D

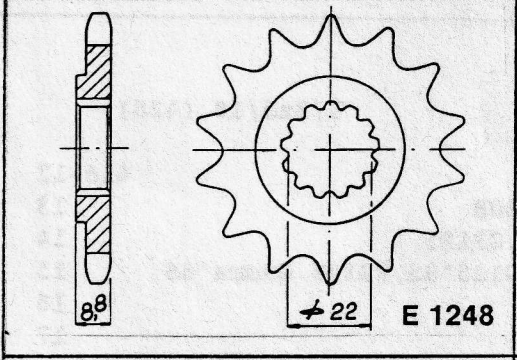

MAICO

5/8x1/4 (520)

250TWIN-LINK
490TWIN-LINK
GM500 '85

1248-11
12
13
14
15
16

204.811
204.812
204.813
204.814
204.815
204.816

E 1248

materiaal: K2D

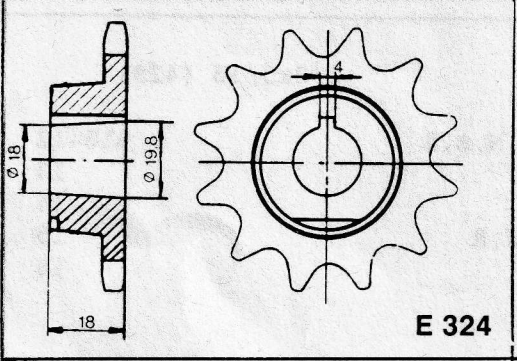

MONTESA

5/8x1/4 (520)

250King Scorpion
250/360 Coppra VA
Cota 348T

324-10
11
12

232.410
232.411
232.412

E 324

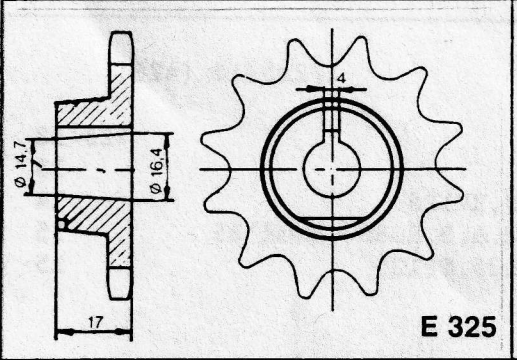

MONTESA

5/8x1/4 (520)

Cota200T
Cota247T

325-09
10
11

232.509
232.510
232.511

E 325

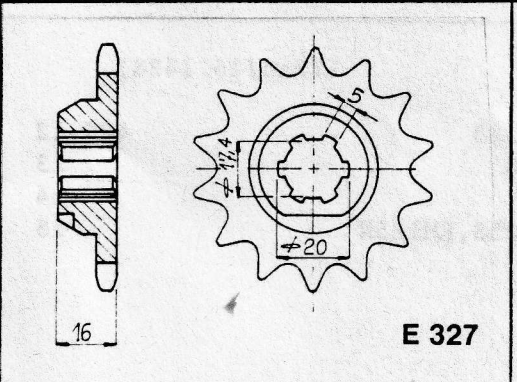

MONTESA

5/8x1/4 (520)

250WE, WB
360ENDURO H

327-10
11

232.710
232.711

E 327

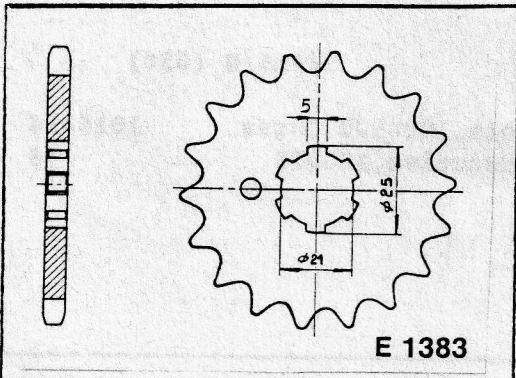

E 1383

OSSA

5/8x1/4 (520)

	1383-11	208.311
MC250/400	12	208.312
PHANTOM SS	13	208.313
DESERT, PIONIER	14	208.314

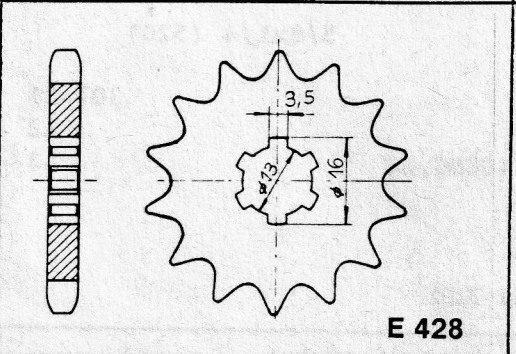

E 428

SUZUKI

1/2x5/16 (428)

RM80,GT80/L,TS80ER	428-14	242.814
	15	242.815
	16	242.816

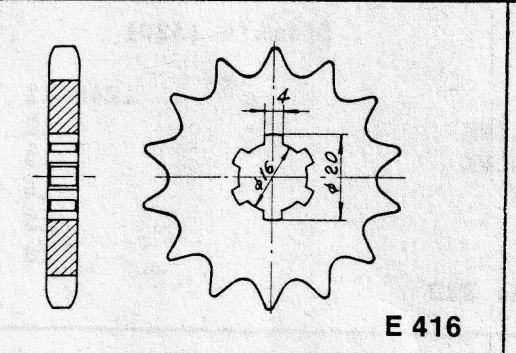

E 416

SUZUKI

1/2x5/16 (428)

RM80XD	416-12	241.612
RM80XZ, RM80H	13	241.613
TS125C, ER, GP125	14	241.614
TS128XE, RG125'85, RG125 Gamma'86	15	241.615
125RX	16	241.616
	17	241.617

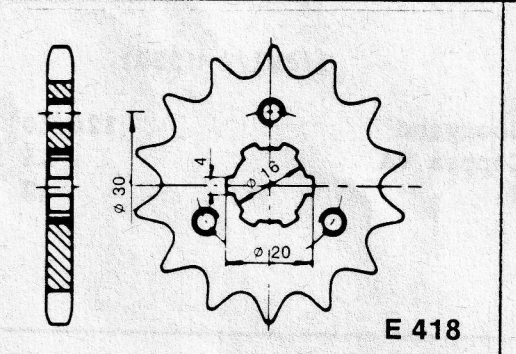

E 418

SUZUKI

1/2x5/16 (428)

RV90K, J, L, M, A, B	418-12	241.812
A100	13	241.813
RV125K, L	14	241.814
TS125K, L, J, R	15	241.815
	16	241.816

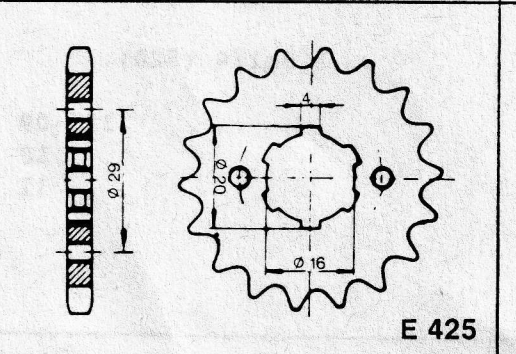

E 425

SUZUKI

1/2x5/16 (428)

	425-12	242.512
TX80XE	13	242.513
TS80X, RV90, RV125	14	242.514
TS125K, L, M, A, B, RG80 Gamma'85	15	242.515
RM125M, GT125, GP125	15	

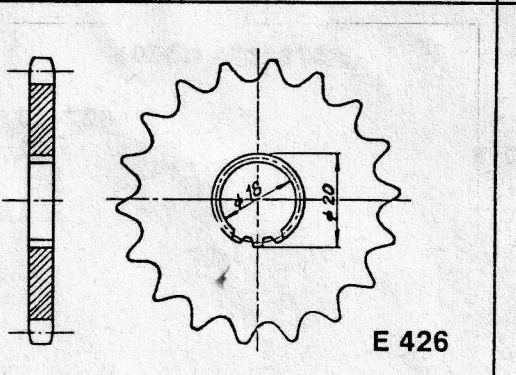

E 426

SUZUKI

1/2x5/16 (428)

RMC125, RV125	426-12	242.612
RM125A, B, C	13	242.613
GS125	14	242.614
GN125, DR125S, RM125N	15	242.615

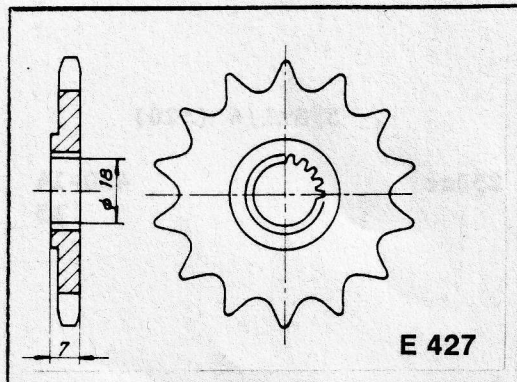

E 427

SUZUKI

5/8x1/4 (520)

RMT125, RMN125, RMX125, RMD125
RM125 '88/89

427-10	242.710
11	242.711
12	242.712
13	242.713

materiaal: K2D

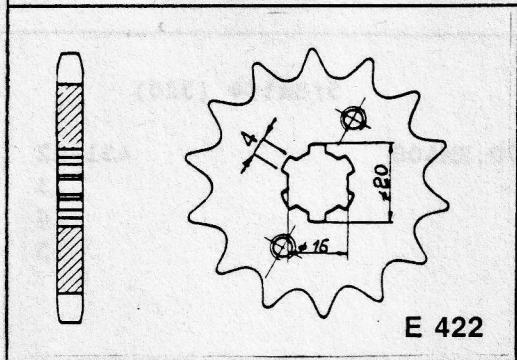

E 422

SUZUKI

5/8x1/4 (520)

GT185
SB200
GT200 X5

422-12	242.212
13	242.213

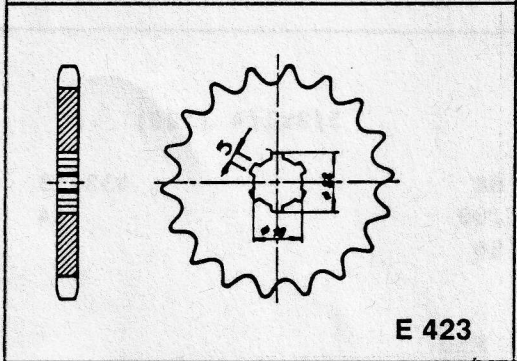

E 423

SUZUKI

5/8x1/4 (520)

RM125, GT185
RM250, RL250
PE250, RM370

423-12	242.312
13	242.313
14	242.314
15	242.315

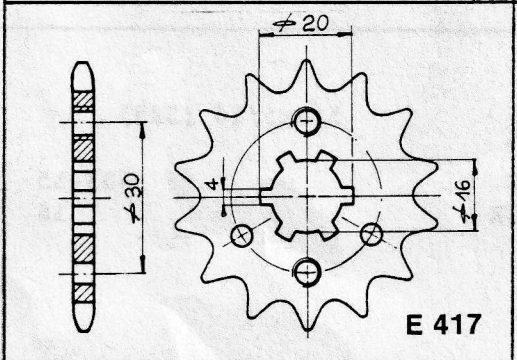

E 417

SUZUKI

5/8x5/16 (525)

T20, TC250, KMX125 '86

417-13	241.713
14	241.714

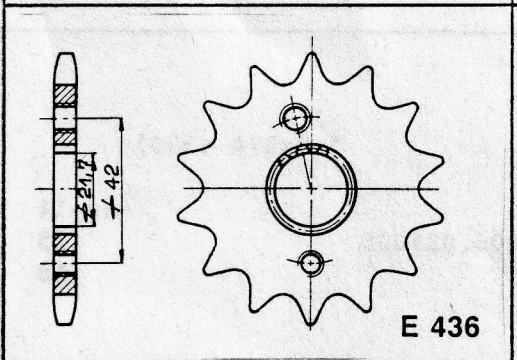

E 436

SUZUKI

5/8x1/4 (520)

RG250WD-WE '85
RG250 Gamma '86/88

436-14	243.614
14	

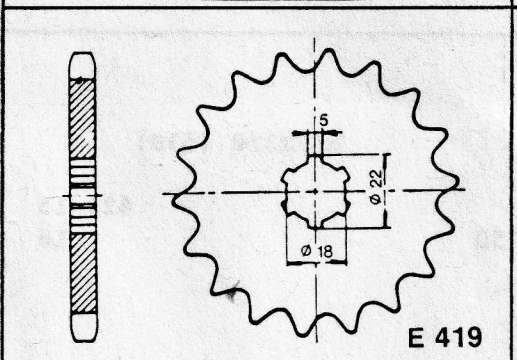

E 419

SUZUKI

5/8x5/16 (525)

T250, GT250
TS250K-A

419-13	241.913
14	241.914
15	241.915
16	241.916

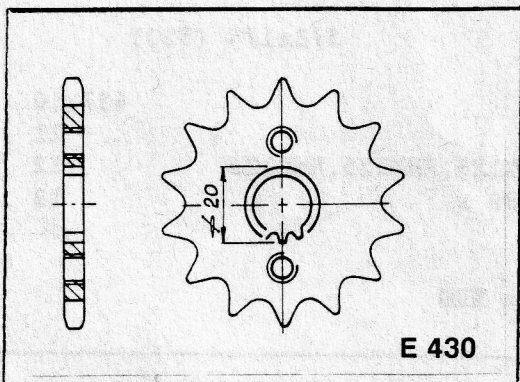

SUZUKI

5/8x1/4 (520)

GSX250, X7 250cc
GT250N-X7

430-14
15

243.014
243.015

E 430

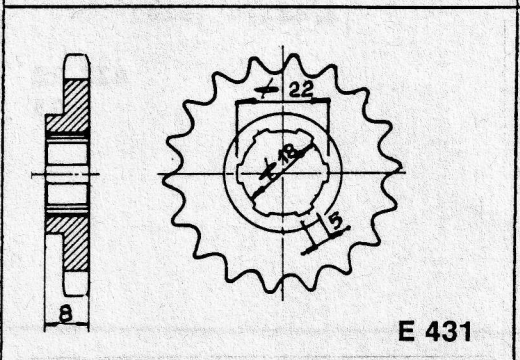

SUZUKI

5/8x1/4 (520)

RM250, RM370, RM400

431-12
13
14
15

243.112
243.113
243.114
243.115

E 431

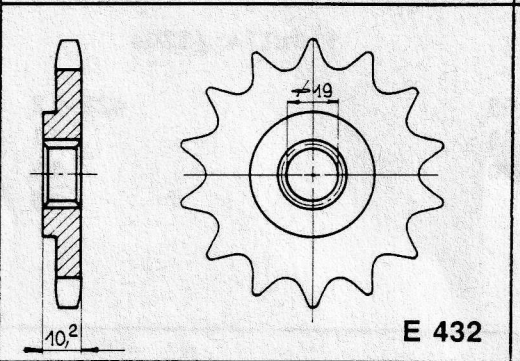

SUZUKI

5/8x1/4 (520)

TS250X-G '88
RN250X '81/88
MX250 '84/86

432-13
14

243.213
243.214

materiaal: K2D

E 432

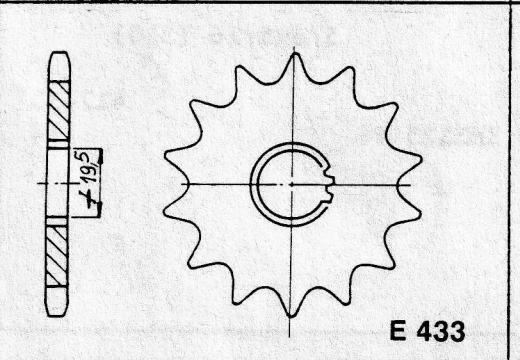

SUZUKI

5/8x5/16 (525)

TS250A, B, C
TS250B, C, ER

433-15
16

243.315
243.316

E 433

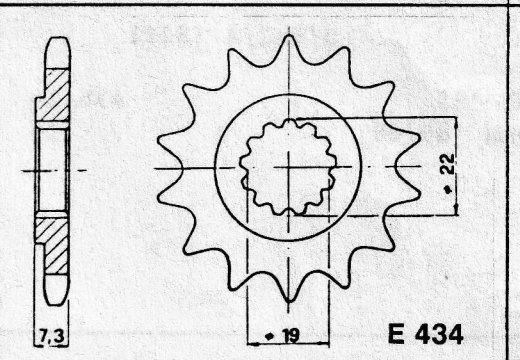

SUZUKI

5/8x1/4 (520)

DR250S
SP370, DR400S, DR500S
GN400TD

434-14
15
16

243.414
243.415
243.416

E 434

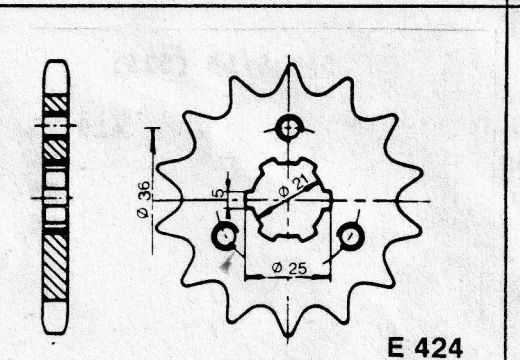

SUZUKI

5/8x3/8 (530)

GT380
GT550, GT750

424-15
16

242.415
242.416

E 424

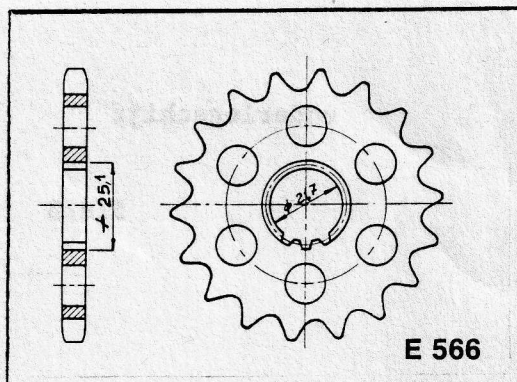

<u>SUZUKI</u>	5/8x3/8 (530)		
GSX550ES/EF,GSX750ES,GSX550EU'86	566-14	15	256.614
GS550,GS550EM,Katana,		15	256.615
GSX750OR'85/86,GSX750F'89		15	
GS400,GS450,GSX400E,RG500		16	256.616
Gamma '86		16	
		17	256.617

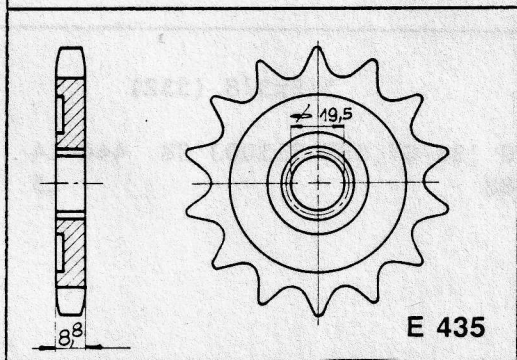

<u>SUZUKI</u>	5/8x3/8 (530)		
GSX400F,GR650/E	435-15	15	243.515

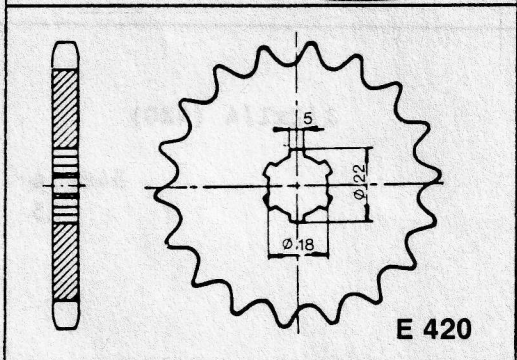

<u>SUZUKI</u>	5/8x3/8 (530)		
GT500L	420-14	15	242.014
T500,GT500		16	242.015
		16	242.016

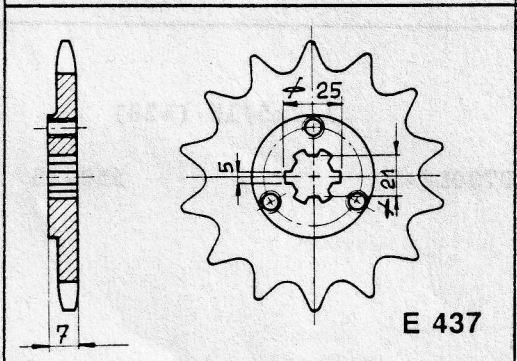

<u>SUZUKI</u>	5/8x1/4 (520)		
DR600S	437-16	15	243.716

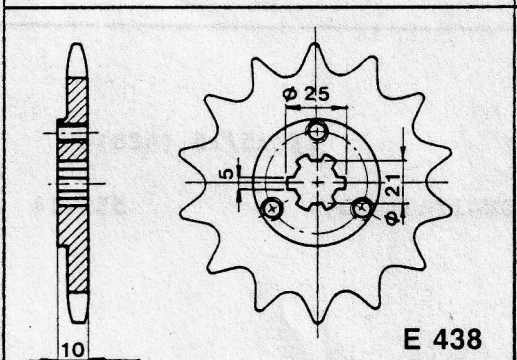

<u>SUZUKI</u>	5/8x1/4 (520)		
DR750	438-15	15	243.815

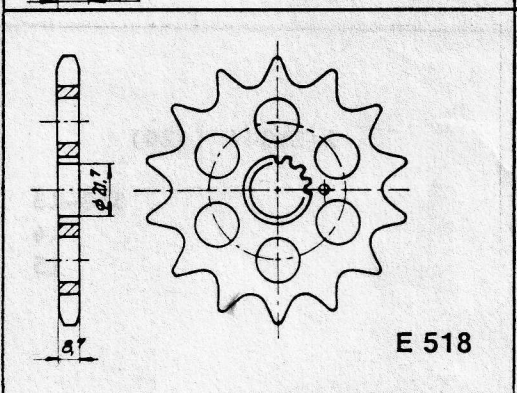

<u>SUZUKI</u>	3/4x3/8 (630)		
GS750,GS1000	518-13	14	251.813
		14	251.814
		15	251.815

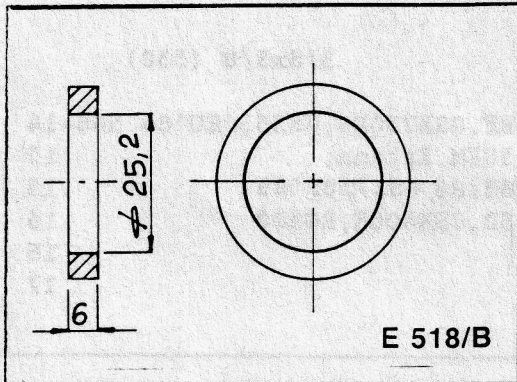

SUZUKI
GSX750
GSX1100

onderlegschiif

518/B 251.816

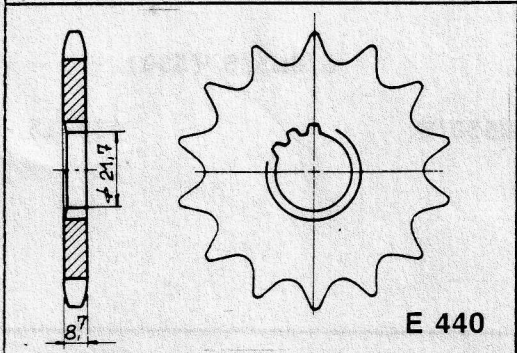

SUZUKI

5/8x3/8 (532)

GSX-R1100G '86/87, GSX-R1100J'88 440-14 244.014
GSX1100F'88 15 244.015

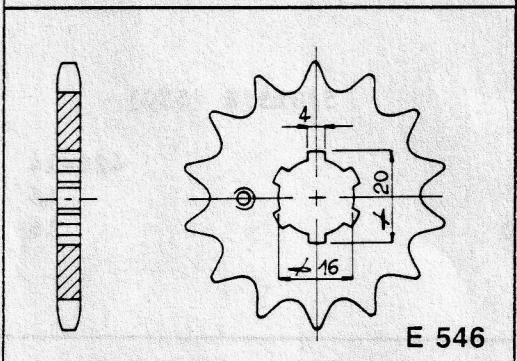

YAMAHA

1/2x1/4 (420)

FS80 546-14 254.614
15 254.615

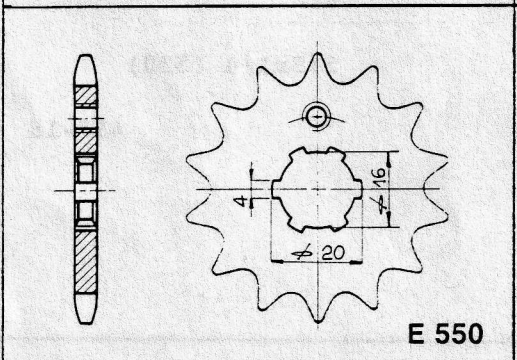

YAMAHA

1/2x5/16 (428)

RD80LC-2, DT80LC-2 550-15 255.015

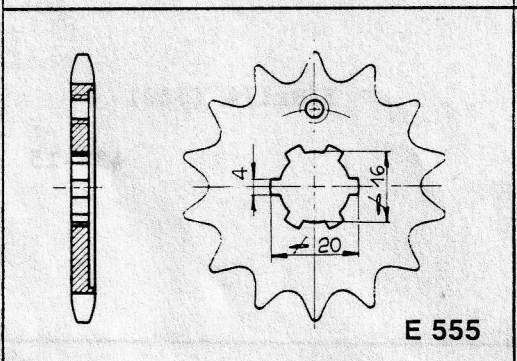

YAMAHA

1/2x5/16 (428)

RD80LC (30W-17461-40) 555-14 255.514

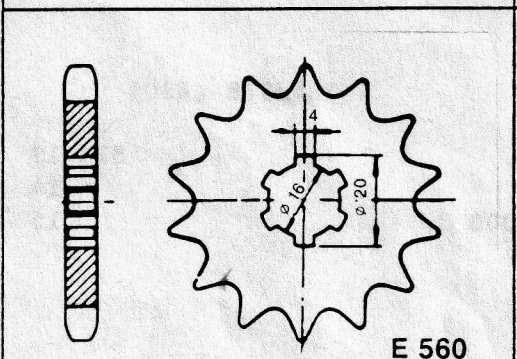

YAMAHA

1/2x1/4 (420)

DT80LC 560-13 256.013
14 256.014
15 256.015

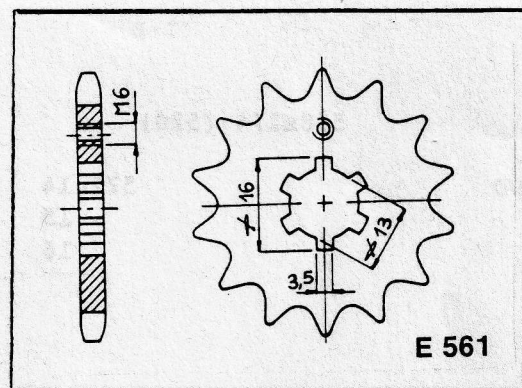

E 561

YAMAHA
RD80, DT80

1/2x1/4 (420)

561-14	256.114
15	256.115
16	251.116

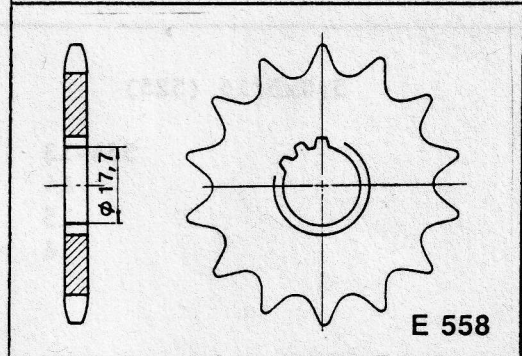

E 558

YAMAHA
DT125

1/2x5/16 (428)

558-15	255.815
16	255.816
17	255.817

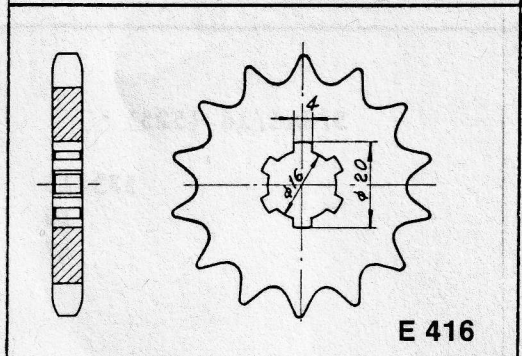

E 416

YAMAHA

1/2x5/16 (428)

RD125, DT125
DT175, R200, TY250

416-12	241.612
13	241.613
14	241.614
15	241.615
16	241.616
17	241.617

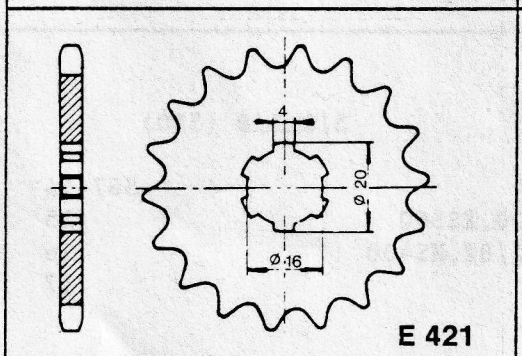

E 421

YAMAHA

5/8x1/4 (520)

YZ125, YZM125

421-11	242.111
12	242.112
13	242.113
14	242.114

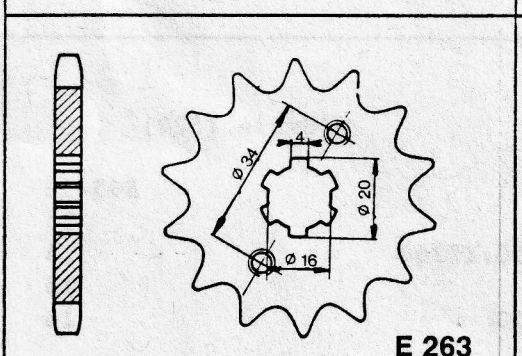

E 263

YAMAHA

1/2x5/16 (428)

XT125'85

RD125LC, DT125LC, TZR125'87

263-13	226.313
14	226.314
15	226.315
16	226.316

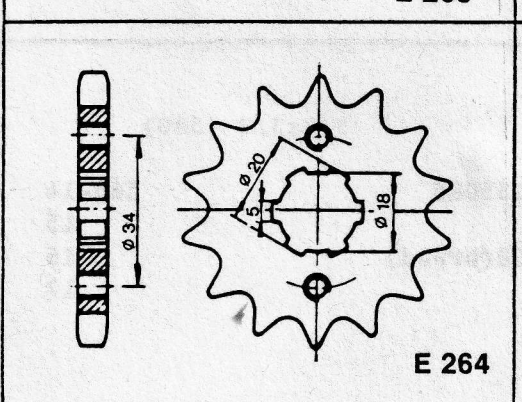

E 264

YAMAHA

1/2x5/16 (428)

DT125 Belgarda '87
DT125 Tenere '89

264-16	226.416
17	226.417

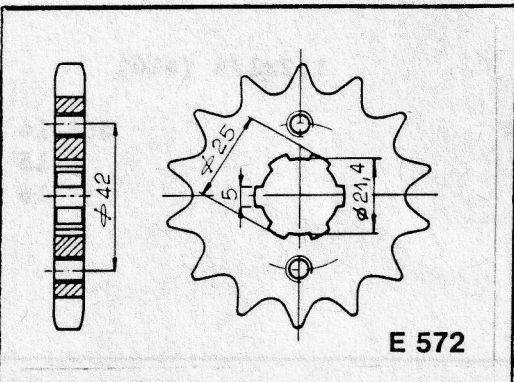

YAMAHA

5/8x1/4 (520)

SR250 '88/90
XT250
SR250

572-14
15
16

257.214
257.215
257.216

E 572

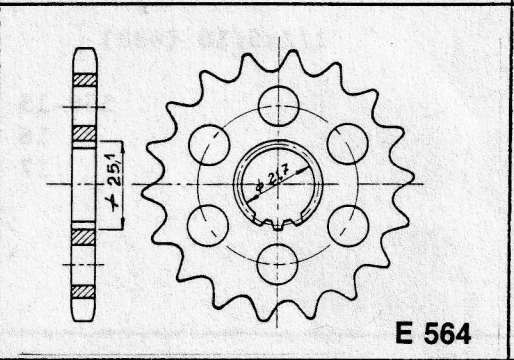

YAMAHA

5/8x5/16 (525)

250DS
350DS

564-13
14
15
16

256.413
256.414
256.415
256.416

E 564

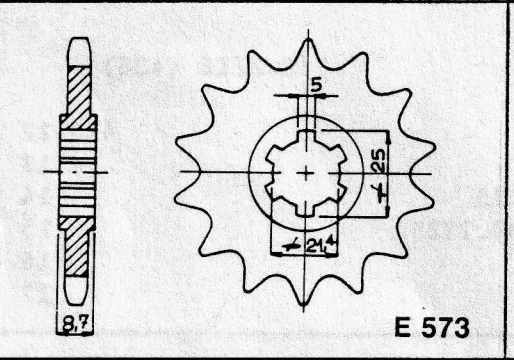

YAMAHA

5/8x5/16 (525)

RD250 1A2
RD250 2R8

573-15
16
17

257.315
257.316
257.317

E 573

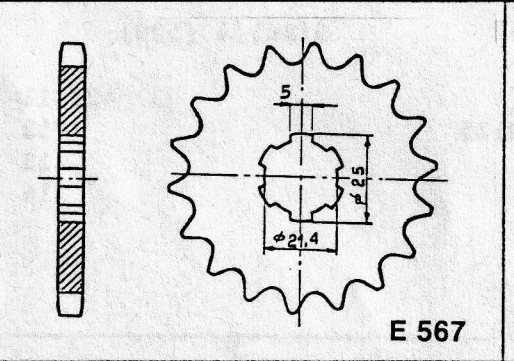

YAMAHA

5/8x3/8 (530)

RD250, RD400, XS360
RD350LC '80/82, XS400

567-14
15
16
17

256.714
256.715
256.716
256.717

E 567

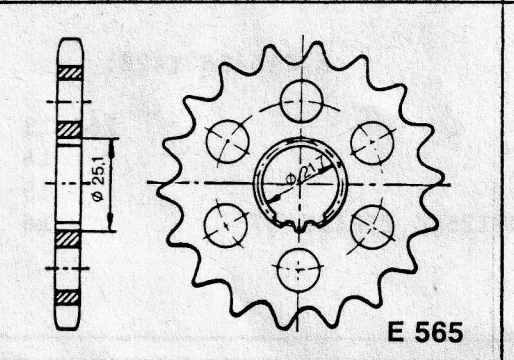

YAMAHA

5/8x1/4 (520)

MX250, YZ250, YZ360
DT400, XT500

565-12
13
14
15
16

256.512
256.513
256.514
256.515
256.516

E 565

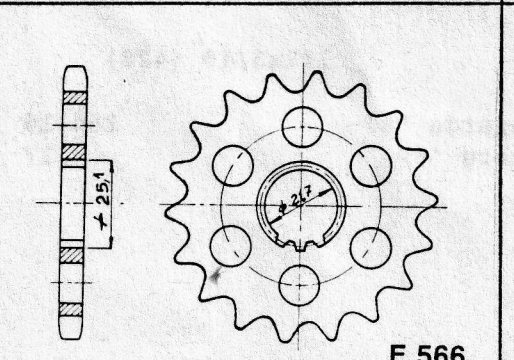

YAMAHA

5/8x3/8 (530)

RD250R6, RD350R6
SR500, XT500 (breed)
XS500

566-14
15
16
17

256.614
256.615
256.616
256.617

E 566

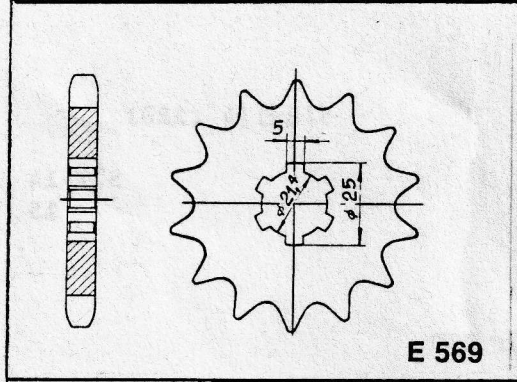

YAMAHA 5/8x1/4 (520)

YZ250/400,DT250/400	569-13	256.913
YZ250'87	14	256.914
	15	256.915
	16	256.916
RD350LC'83/88	17	256.917

materiaal: K2D

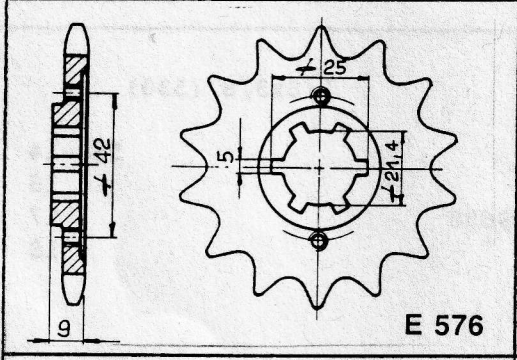

YAMAHA 1/2x5/16 (428)

XT350(55V-17461-90)	576-19	257.619
---------------------	--------	---------

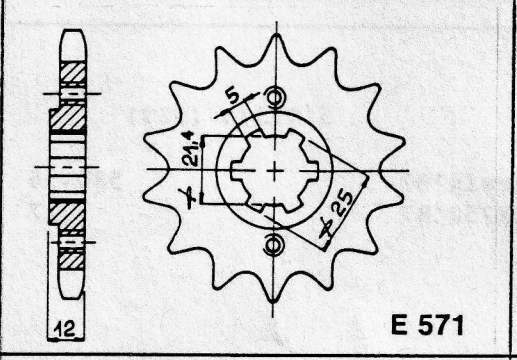

YAMAHA 5/8x3/8 (530)

XJ400, XS400 DOHC, XJ550 XJ600	571-16	257.116
-----------------------------------	--------	---------

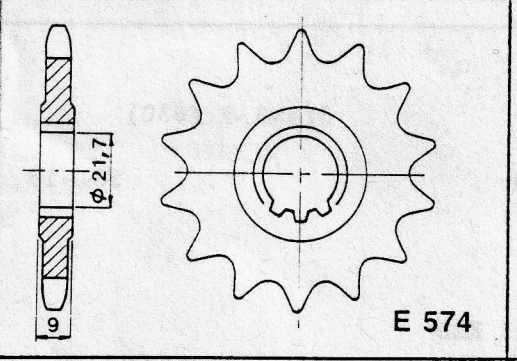

YAMAHA 5/8x5/16 (525)

FZR400'88	574-15	257.415
-----------	--------	---------

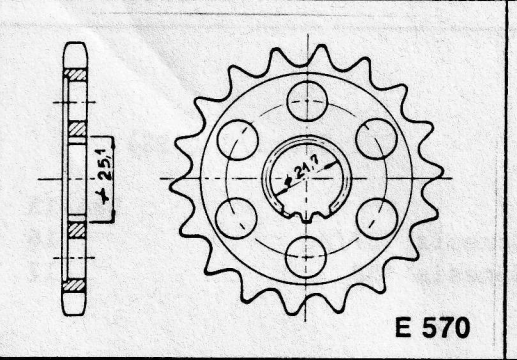

YAMAHA 5/8x3/8 (530)

XT500	570-14	257.014
	16	257.016

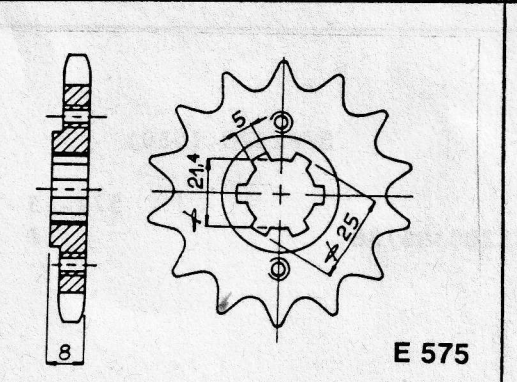

YAMAHA 5/8x1/4 (520)

TT600	575-14	257.514
XT550, XT600, SRX600	15	257.515
XT600 4 Valv.'85, SRX600'86	15	
	16	257.516

materiaal: K2D

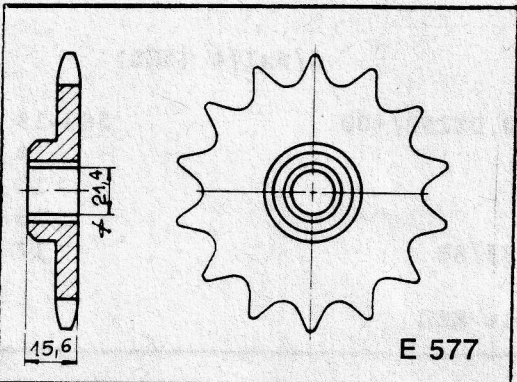

YAMAHA 5/8x1/4 (520)
 XT600'87 577-14 257.714
 15 257.715
 materiaal: K2D

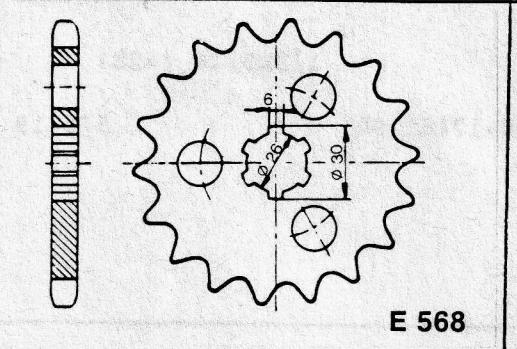

YAMAHA 5/8x3/8 (530)
 TX750 568-14 256.814
 XS1, XS2, XS650 16 256.816
 17 256.817
 18 256.818

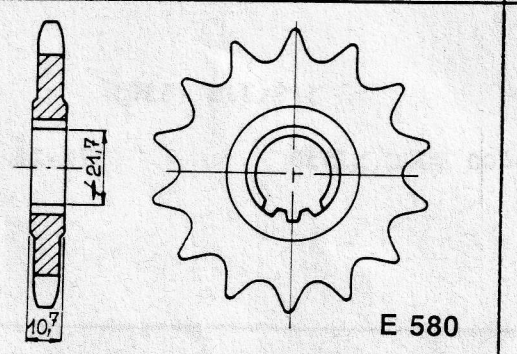

YAMAHA 5/8x3/8 (530)
 FZ750 Genesis'87 580-16 258.016
 FZ750, FZX750'87 17 258.017

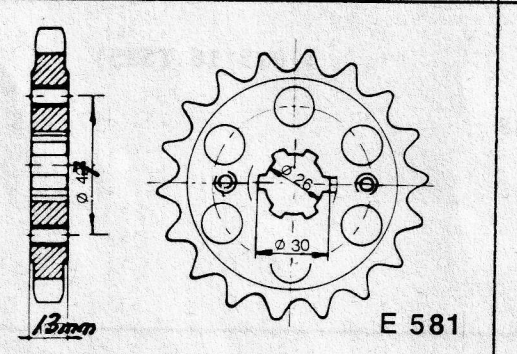

YAMAHA 3/4x3/8 (630)
 XV1000'89 581-16 258.116
 materiaal: K2D

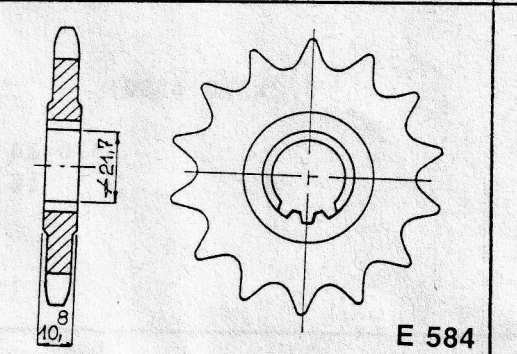

YAMAHA 5/8x3/8 (532)
 FZR1000 Genesis '87/88 584-15 258.415
 FZR1000 Genesis '88 16 258.416
 17 258.417

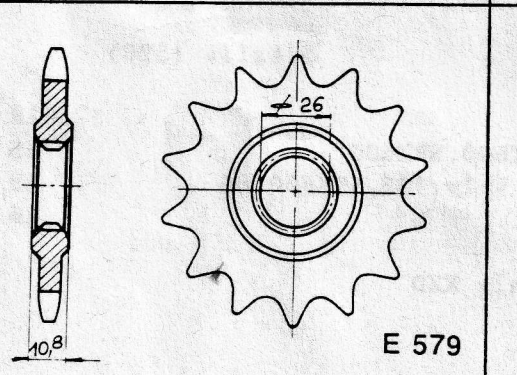

YAMAHA 5/8x3/8 (530)
 RD500LC 579-15 257.915
 FJ1100, FJ1200'86/88 17 257.917

ZUNDAPP

1/2x5/16 (428)

KS125

484-15

248.415

GS125

16

248.416

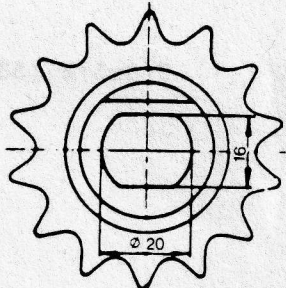

E 484
